

# Brakemaster® 350

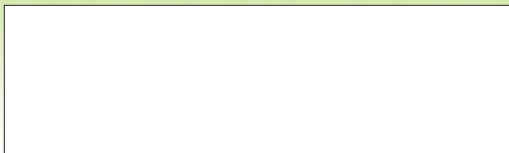

*Easy - to - install Guardrail End Treatment,  
Meets NCHRP 350, TL-3!*



**ENERGY ABSORPTION  
SYSTEMS, INC.**

*A Quixote Company  
Saving Lives By Design*

**Corporate Offices:**

35 East Wacker Dr., 11th Floor  
Chicago, IL 60601-2076

Telephone: (312) 467-6750

FAX: (312) 467-1356

<http://www.energyabsorption.com/>

**Engineering and Manufacturing Facilities:**

Rocklin, CA

Pell City, AL

**Installation/Maintenance**

# Brakemaster® 350

## Table of Contents

System Introduction/Overview .....	2
Required Tools .....	3
Site Preparation.....	4
System Drawing Unidirectional Configuration....	5
System Drawing Bidirectional Configuration.....	5
Typical Transition Sections.....	6
Installation Procedures.....	7
Anchor Installation.....	7
Unidirectional System Assembly.....	12
Bidirectional System Assembly.....	18
System Adjustment.....	25
Checking The System Assembly.....	25
Maintenance Checklist .....	26
Post-Impact Instructions .....	27
Brakemaster 350 Description.....	28
Components .....	29
Limitations and Warnings .....	32

## Important Introductory Notes

Proper installation of the Brakemaster 350 System is essential to assure maximum performance. Take the time to review the installation instructions and product limitations thoroughly before performing the necessary work. Do not attempt to install any crash cushion without the proper plans and installation manual from the manufacturer.

If you need additional information, or have questions about the Brakemaster 350 System, please call Energy Absorption Systems' **Customer Service Department at (888) 32-ENERG**.

## System Overview

The Brakemaster 350 System is specially designed to shield narrow hazards in low frequency impact areas (see Limitations and Warnings). For protection of narrow hazards in a greater number of applications and easier refurbishment, the QuadGuard® System remains the most versatile impact attenuator available.

## Crash Performance

The Brakemaster 350 System has successfully passed the NCHRP 350, Test Level 3 tests for redirective gating crash cushion with both the light car and pickup truck at speeds up to 100 km/h [62 mph] at angles up to 20 degrees.

During head-on impacts, the Brakemaster 350 System telescopes rearward and impact energy is absorbed through momentum transfer, friction and metal deformation. When impacted from the side, the System is restrained from lateral movement by dynamic tension developed between end restraints.

# Required Tools

1. This installation manual
2. Installation plans (prints) for this type of System
3. Crescent wrenches (two 300 mm [12"])
4. Pipe wrenches (two 600 mm [24"])
5. 1/2" or 3/4" drive ratchet with extension, 15/16", 1 1/4", 1 3/8", and 1 7/16" deep sockets
6. 15/16" and 1 3/8" combination wrenches
7. Drift pin (to align holes)
8. Boom or forklift with minimum 700 Kg [1500 lb] capacity (recommended for handling packaged System and for positioning the Brake Tension Support)
9. Gas welder with cutting torch (recommended if transition modifications are required)
10. 15,000 mm [50 ft] tape measure
11. Generator
12. Traffic control equipment
13. Drill motor with 50 mm [2"] dia wood auger bit and 11/16" drill bit
14. Drilling rig with 200 mm [8"] (for drivable tube anchor) or 600 mm [2'] (for embedded anchor) dia auger for 1500 mm [5'] deep hole
15. Gloves
16. Chalk line
17. Safety glasses
18. Bubble level
19. 24" carpenter's level

*Note: The above list of tools is a general recommendation. Depending on specific site conditions and type of System being installed more or fewer tools may be required.*

## How to Determine Left/Right

To determine left from right when ordering parts, stand in front of the System facing the hazard. Your left is the System's left and your right is the System's right.

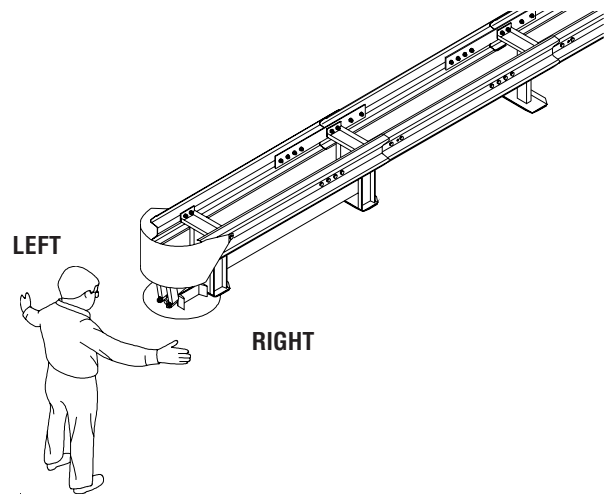

**Figure 1**  
*Left\Right*

## Counting the Number of Bays

One bay consists of one diaphragm, two fender panels, etc. Determine the number of bays by counting the fender panels on one side.

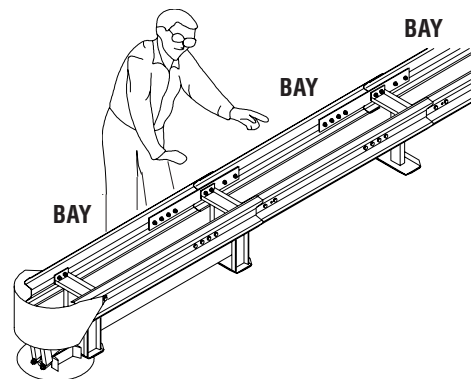

**Figure 2**  
*Number of Bays*

# Brakemaster<sup>®</sup> 350

## Site Preparation

The BRAKEMASTER 350 System (Figure 3) must be installed on soils having a strength in the range of 10 to 60 blow counts per 305 mm [foot] (per ASTM D1586) with the anchorage described in this installation manual. For soils with differing blow counts per foot, refer to the design manual for the increased capacity designs. The location and orientation of the BRAKEMASTER 350 System must comply with the project plans or as otherwise specified by the resident engineer. Installation cross-slope shall not exceed 8% (4.5 degrees). The pad surface finish shall be compacted soil, compacted subbase, oiled crushed rock, asphalt, or concrete.

*Note: Upon impact, the fender panels of the BRAKEMASTER 350 System telescope and can extend rearward beyond the guardrail or transition end as much as 1830 mm [6'] from their pre-impact position. Position the BRAKEMASTER 350 System end point so that the ends of the last fender panels are a minimum of 1830 mm [6'] forward of objects that would interfere with movement of the fender panels. Failure to comply with this requirement can result in impaired System operation and possible bodily injuries during an impact.*

The BRAKEMASTER 350 System has a 533 mm [21"] w-beam center height and may require a transition section to connect to existing guardrail. Refer to the design manual for the proper design of the transition section. See page 6 (Figure 6) of this manual for standard transition sections.

### KEY

1. ANCHOR ASSEMBLY
2. BRAKE/TENSION SUPPORT (BTS)
3. W-BEAM FENDER PANEL
4. DIAPHRAGM
5. TENSION STRAP
6. NOSE COVER

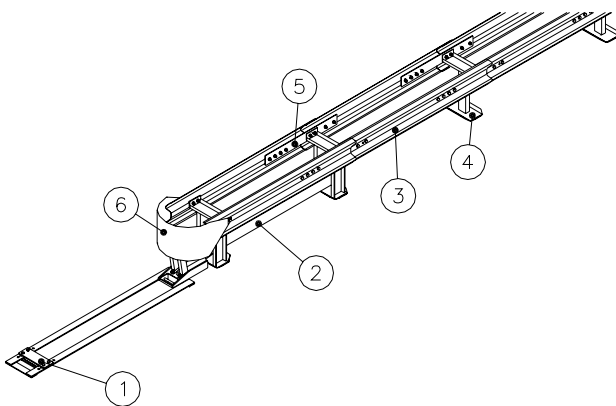

**Figure 3**  
**Number of Bays**

# System Drawings

*Note: The unidirectional configuration of the BRAKEMASTER 350 System uses two transition straps, two solid straps and six laminated straps. After installing the System in a unidirectional configuration, one solid strap will be left unused. See page 12 for unidirectional installation procedures.*

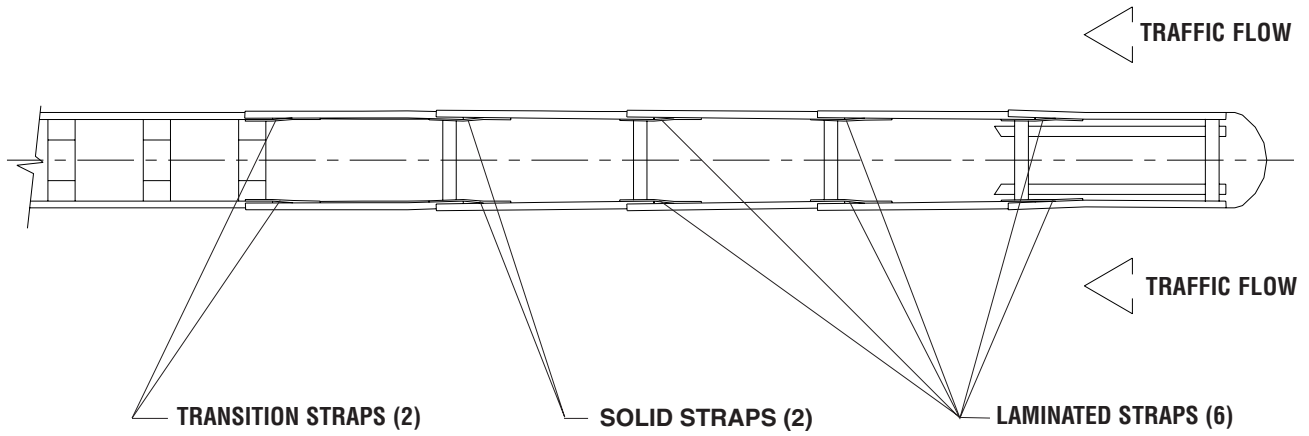

**Figure 4**  
*Unidirectional Configuration of the BRAKEMASTER® 350 System*

*Note: The Bidirectional configuration of the BRAKEMASTER 350 System uses one transition strap, three solid straps and five laminated straps. After installing the System in a bidirectional configuration one transition strap and one laminated strap will be left unused. See page 18 for bidirectional installation procedures.*

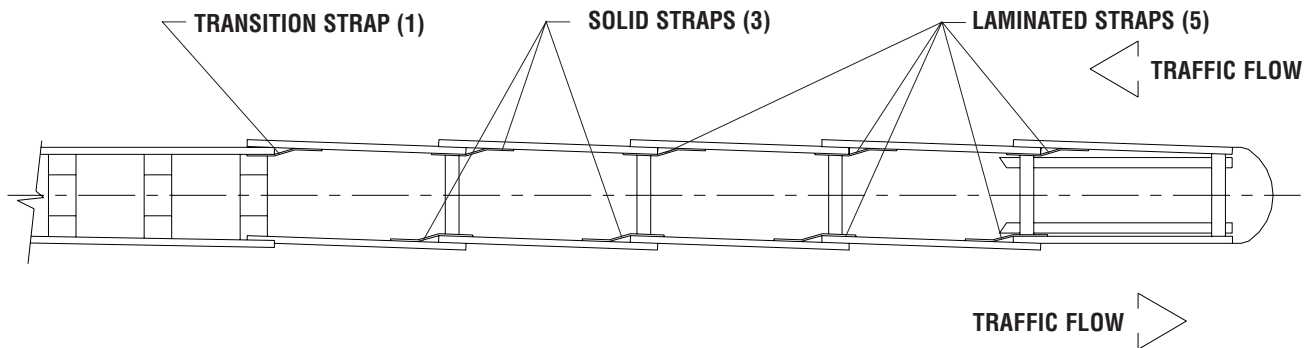

**Figure 5**  
*Bidirectional Configuration of the BRAKEMASTER 350 System*

# Brakemaster® 350

**CAUTION: THE BRAKEMASTER SYSTEM MUST NOT BE ATTACHED DIRECTLY TO A RIGID CONCRETE WALL WITHOUT A TRANSITION SECTION (SEE FIGURE 6), REFER TO DESIGN MANUAL.**

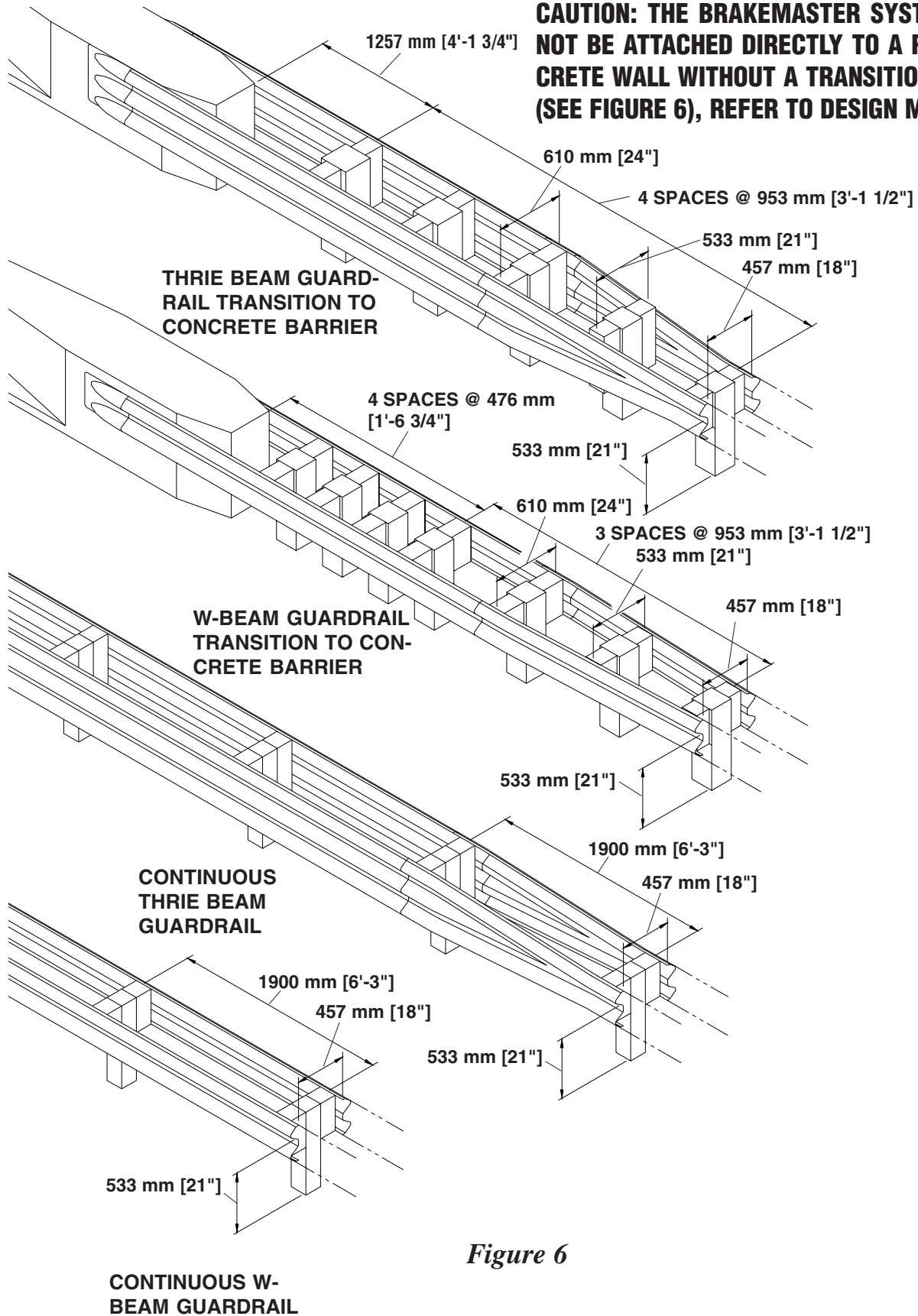

*Figure 6*

# Installation Procedures

## Drivable Foundation Tube Anchor Installation

Upon arrival at site, correctly position the proper traffic control equipment.

*Note: Positioning the front anchor relative to the guardrail end is critical for ease of installation.*

*Note: To ensure proper performance, the BRAKEMASTER® 350 System must be properly anchored. The standard anchor for the BRAKEMASTER 350 System is the drivable foundation tube anchor system (Figure A-1). Other anchors are available. Please contact Energy Absorption Systems Customer Service Department at (888) 32-ENERG for additional information.*

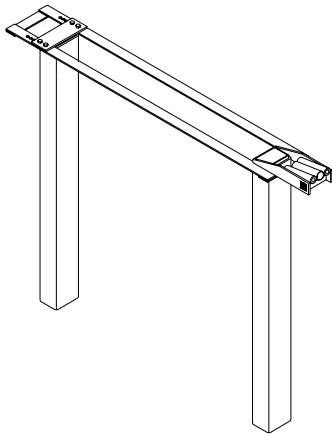

**Figure A-1**  
Foundation Tube Anchor

In general terms, the process of installing the anchor system for a BRAKEMASTER 350 System has four stages:

- A. Establishing a proper work zone.
- B. Positioning and aligning the anchor system.
- C. Driving the foundation tubes accurately.
- D. Assembling the remainder of the anchor system.

## Drivable Foundation Tube Anchor Installation Steps

*(An alternate method using an embedded anchor is shown on pages 10-11)*

### 1) Stage A - Establish a Proper Work Zone

Upon arrival at site, correctly position the proper traffic control equipment, in accordance with applicable local, state, and/or Federal regulations.

*Note: Positioning the front anchor relative to the guardrail end is critical for ease of installation.*

### 2) Stage B – Position and Align the Anchor System

*Note: The standard foundation tube anchor must be installed in adequate soil (see Design manual for description of range of acceptable soil conditions). Do not attempt to install the foundation tube anchor in rocky or extremely stiff soils because irreversible damage to the anchor may result. The resident engineer should specify the appropriate anchor design.*

**Caution: Use gloves when handling metal parts.**

**Determine the System centerline as shown in Figure A-2. System centerline shall be the guardrail centerline.**

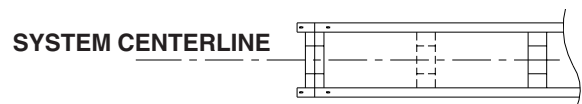

**Figure A-2**  
Determine System Centerline

# Brakemaster® 350

To determine the position of the foundation tube anchor assembly, the rear measurement point will be the vertical centerline of the 8 hole pattern on the existing guard-rail end (Figure A-3).

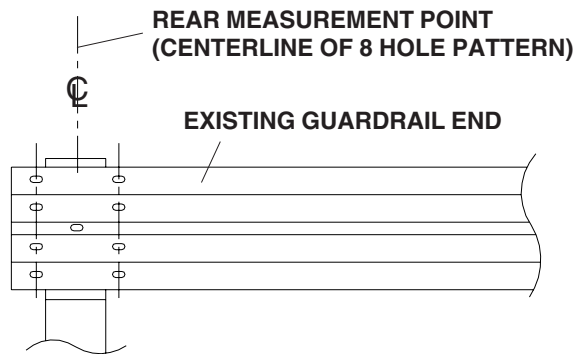

**Figure A-3**

From the rear measurement point, measure forward 9957 +/- 25 mm [32'-8" +/- 1"] along the System centerline to locate the first foundation tube position. From this point, measure forward 1905 +/- 25 mm [6'-3" +/- 1"] along the System centerline to locate the second foundation tube position. At these positions, auger 2 holes 203 mm [8"] maximum diameter by 1981 mm [6'-6"] deep (Figure A-4).

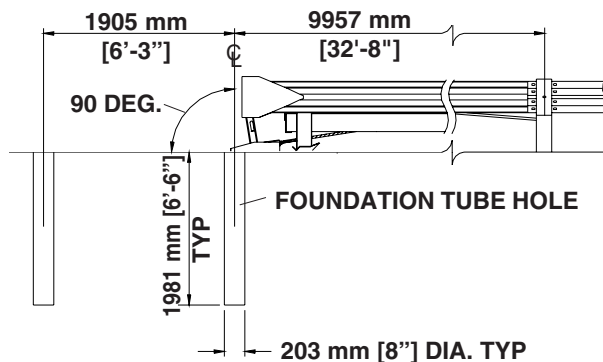

**Figure A-4**

Remove the excess soil and level a 1219 mm [4'] diameter area around the hole.

### 3) Stage C - Driving the Foundation Tubes Accurately

*Note – The following steps assume that a pilot hole is augured prior to driving the foundation tubes into place. If a foundation tube is to be driven directly, i.e. without a pilot hole, caution must be exercised not to damage the upper end of the foundation tube. Damage to the upper end of the foundation tubes may make it difficult to insert the bolts attaching the Anchor Plug and the Anchor Adaptor to their respective foundation tubes.*

Lift the foundation tube into position with the holes in tube at top and perpendicular to System centerline. Using a carpenter's level against the side of the foundation tube, adjust the foundation tube in the hole until it is plumb in both directions (Figure A-5).

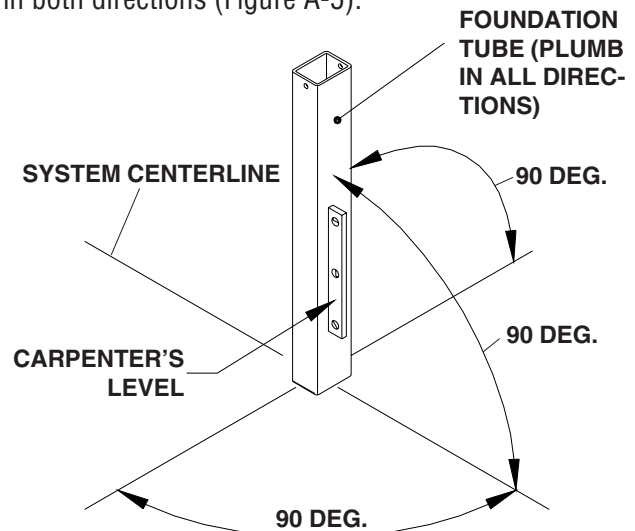

**Figure A-5**

Bring the guardrail post pile driving rig into position alongside the foundation tube. Check again to make sure the foundation tube is plumb in both directions (Figure A-5) then give it one or two moderate blows with the drop hammer. Recheck the foundation tube alignment and if

necessary nudge the foundation tube back into alignment using the bottom of the drop hammer cage. Continue driving until the foundation tube's top is even with the grade (Figure A-6). Follow the same procedure for both tubes.

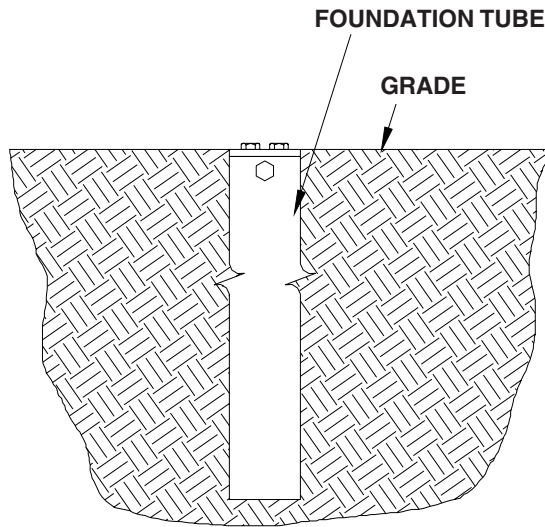

*Figure A-6*

**Caution:** The foundation tube anchor must not protrude above grade level of adjacent ground.

*Note:* Position the drop hammer centered on and plumb with the foundation tube while driving.

#### 4) Stage D - Assembling the Remainder of the Anchor System

Remove enough earth from tube sides to install adaptor bolts. Assemble remaining anchor hardware. A decal marks the rear of the anchor adapter. (Figure A-7).

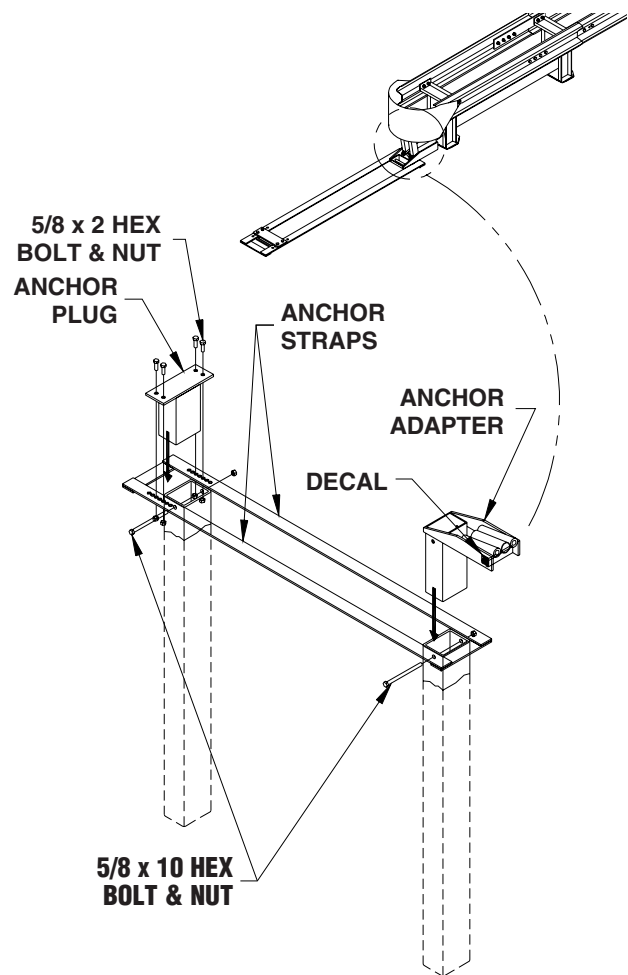

*Figure A-7*

# Brakemaster® 350

## Embedded Anchor Installation

**Note:** The embedded anchor must be installed in strong soil conditions (10 to 60 blow counts per 305 mm [foot] per ASTM D 1586; See Design Manual). The resident engineer should specify the appropriate anchor design.

### Caution: Use gloves when handling metal parts.

Determine the System centerline as shown on the plans (Figure A-8).

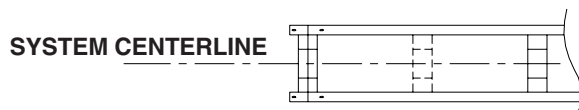

Figure A-8

To determine the embedded anchor position, the rear measurement point will be the vertical centerline of the 8 hole pattern on the existing guardrail end (Figure A-9).

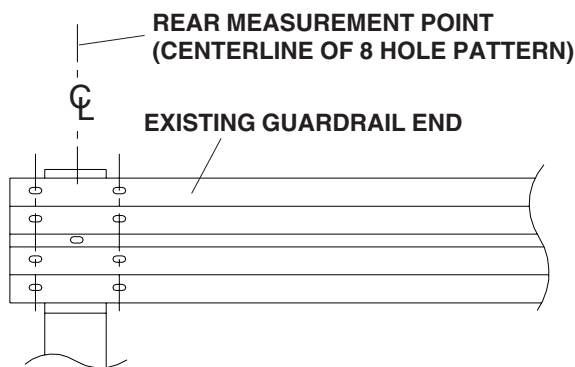

Figure A-9

From the rear measurement point, measure forward 9600 mm +/- 25 mm [31'-6" +/- 1"] along the System centerline to locate the embedded anchor position. Auger a 610 mm [2'] diameter hole 1500 mm [5'] deep (Figure A-10).

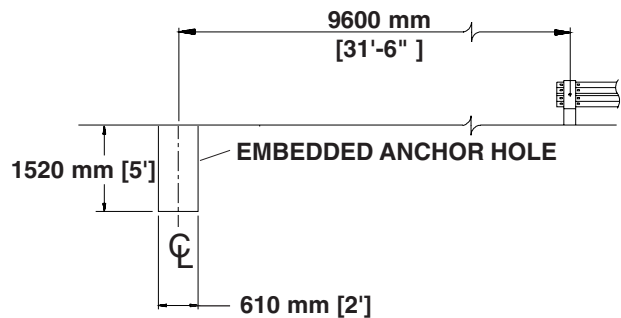

Figure A-10

Remove the excess soil and level a four foot area around the hole.

Attach 1 x 4 boards to the sides of the embedded anchor with the hex head screws provided. Position the embedded anchor over the center of the hole.

**Note:** The anchor must be facing the front for proper operation (Figure A-11). A decal marks the rear of the anchor.

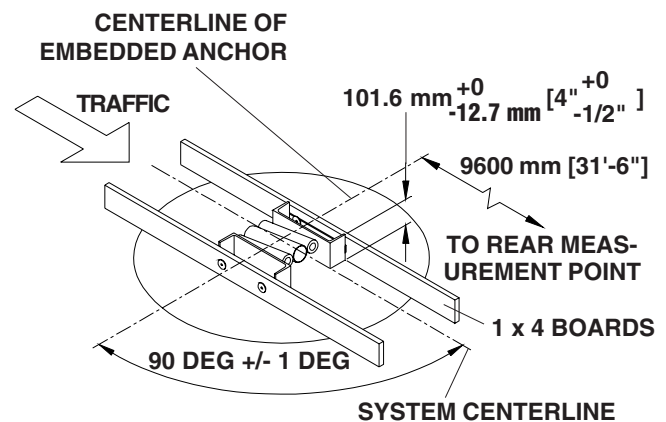

Figure A-11

Align the embedded anchor with the System centerline and position it at 9600 mm +/- 25.4 mm [31'-6" +/- 1"] from the rear measurement point to the center of the anchor.

To ease later nut installation, place a 2 x 4 or similar board between the 1 x 4's 100 mm [4"] ahead of the front holes of the anchor.

Fill the hole with 28 MPa [4,000 psi] minimum strength concrete (cure times of concrete may vary).

Clean off the embedded anchor and level the concrete surface around it.

**Caution: The embedded anchor must not protrude more than 100 mm [4"] above grade level of adjacent ground.**

**Caution: Concrete must be allowed to cure 3 days before the System can be tensioned and placed in service.**

Prepare the rear cable attachment point by drilling 50 mm [2"] diameter holes through wood guardrail posts (Figure A-12), or by cutting 50 mm [2"] diameter holes through steel guardrail posts. (Pipe sleeves are not required in these holes - see page 17, Figure A-31).

**Caution: Use proper precautions when drilling through treated wood posts. Treat the hole with a wood preservative.**

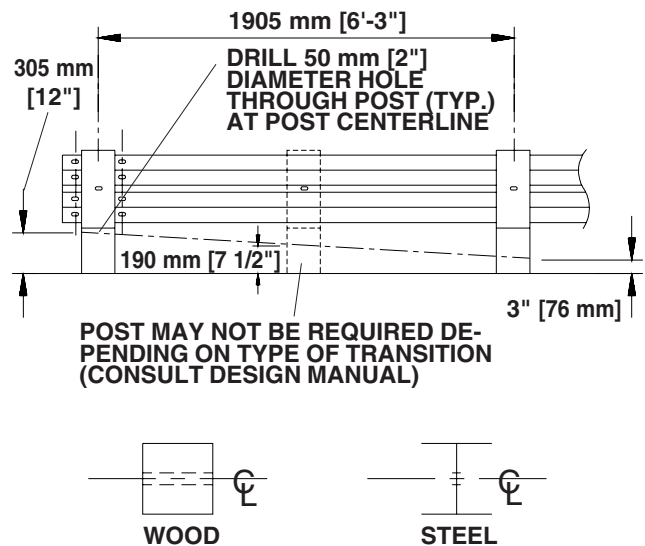

*Figure A-12*

# Brakemaster<sup>®</sup> 350

## BRAKEMASTER System Assembly

**Caution:** Installation of unidirectional and bi-directional Systems configurations are different. For bidirectional configurations, where cars travel in opposite directions on either side of System, refer to the bidirectional configuration section of this manual.

### Unidirectional Installation

*Note:* Begin the assembly of the System at the existing guardrail or transition section and work towards the nose of the System.

Adjust the downstream guardrail sections to bring the left and right side of the guardrail ends into perpendicular alignment  $\pm 12$  mm [ $\pm 1/2$ "] (Figure A-13).

Attach transition straps to the inside of the guardrail ends with four Grade 5, 5/8" hex head bolts, washers, and nuts (Figure A-14).

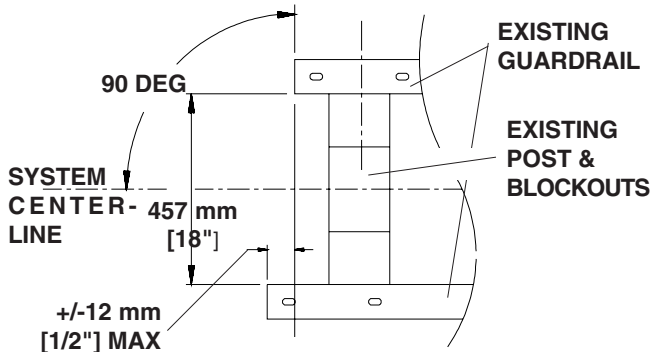

Figure A-13

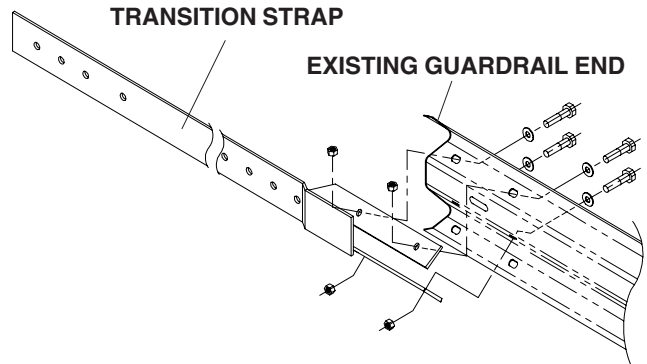

Figure A-14

Make sure that the transition strap ends are in perpendicular alignment with each other  $6$  mm [ $\pm 1/4$ "]. To make these alignment measurements easier, a diaphragm may be temporarily bolted between the transition straps (Figure A-15).

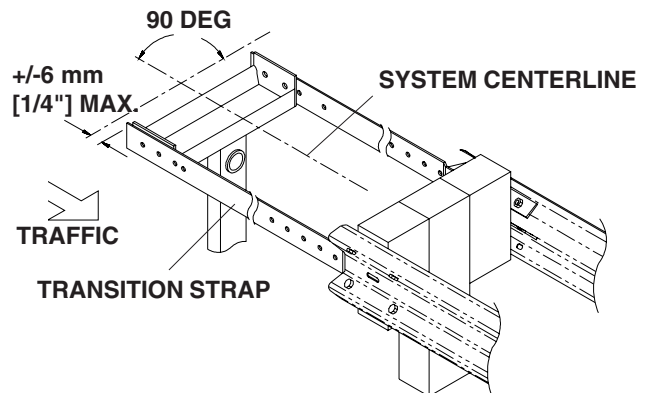

Figure A-15

*Note:* If the perpendicular alignment of the transition straps is not within  $\pm 6$  mm [ $1/4$ "] the downstream guardrail will need to be adjusted. This can be accomplished by loosening the center bolts on the guardrail posts and by moving the guardrail in the appropriate direction.

Tighten the transition strap bolts to approximately 80 Nm [60 ft-lbs].

Remove the temporarily placed diaphragm from between the transition straps.

Attach a fender panel to each transition strap using five Grade 5, 5/8" hex head bolts and nuts (Figure A-16). The forward panel knockout hole must be used.

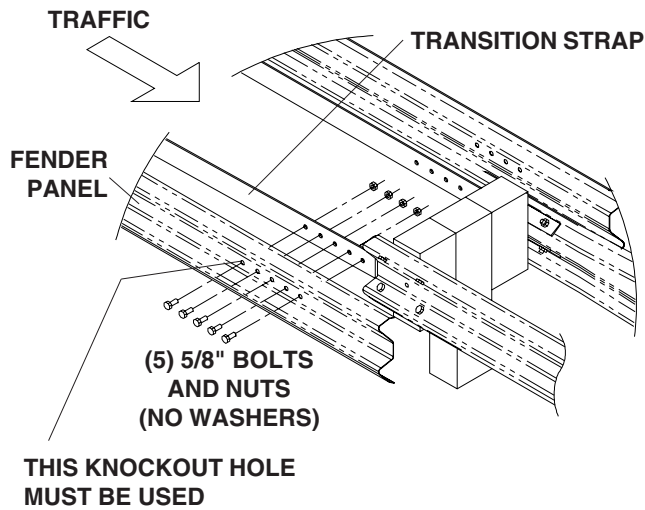
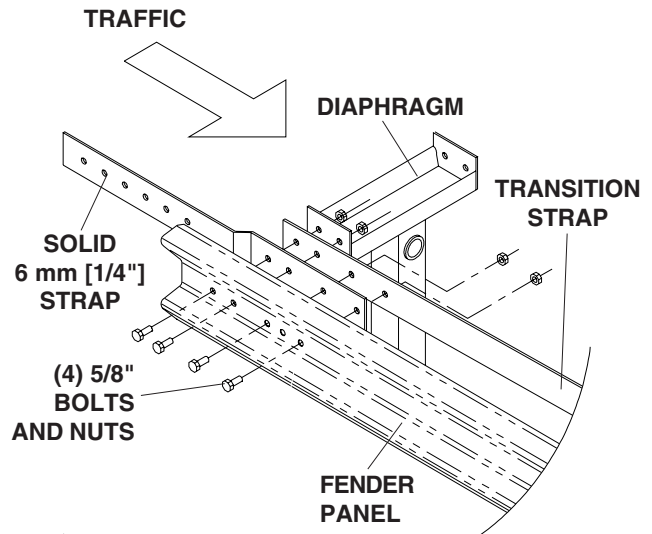

*Figure A-16*

**Caution: For proper impact performance do not use washers on any of the panel connections.**

Position a diaphragm between the front ends of the fender panels and place the solid 6 mm [1/4"] thick by 127 mm [5"] wide straps between the panels and the transition straps (Figure A-17).

Bolt each strap in place using four Grade 5, 5/8" bolts and nuts.

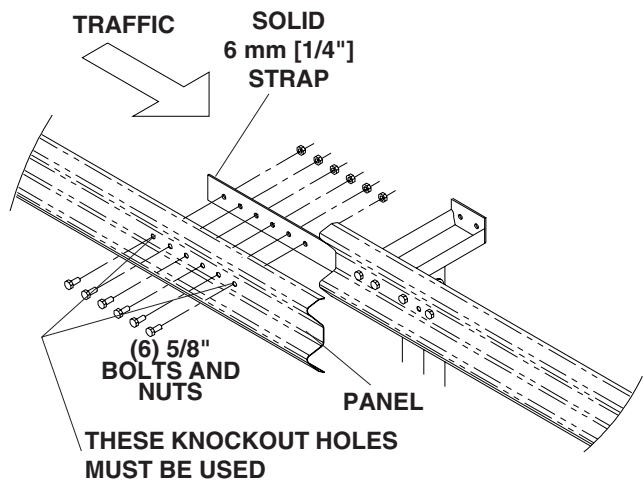

*Figure A-17*

*Note: Torque the panel bolts to approximately 80 Nm [60 ft-lbs] in the following sequence.*

- a.) *First, tighten the bolts passing through the diaphragm.*
- b.) *Then tighten all other bolts.*

Attach a fender panel to the exposed portion of each 6 mm [1/4"] thick strap using six Grade 5, 5/8" bolts and nuts (Figure A-18). Both panel knockout holes must be used.

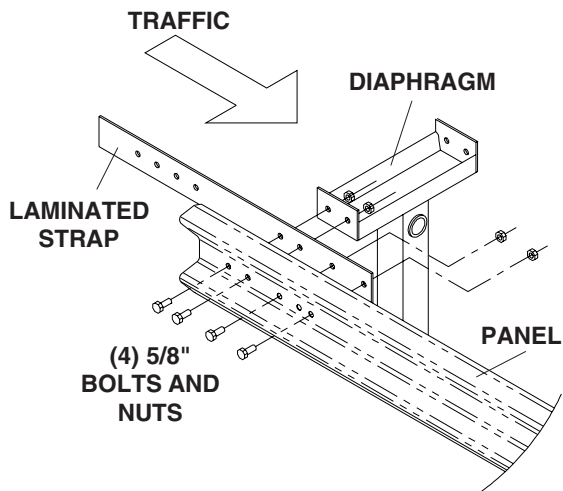

*Figure A-18*

# Brakemaster<sup>®</sup> 350

Position another diaphragm between the front ends of the fender panels and place laminated straps between the fender panels and the diaphragms.

Bolt each set of laminated straps in place using four Grade 5, 5/8" bolts and nuts (Figure A-19).



*Figure A-19*

Repeat the bolt tightening sequence per note (a) and (b) on page 13.

Attach a fender panel to the exposed portion of each set of laminated straps using four Grade 5, 5/8" bolts and nuts (Figure A-20).

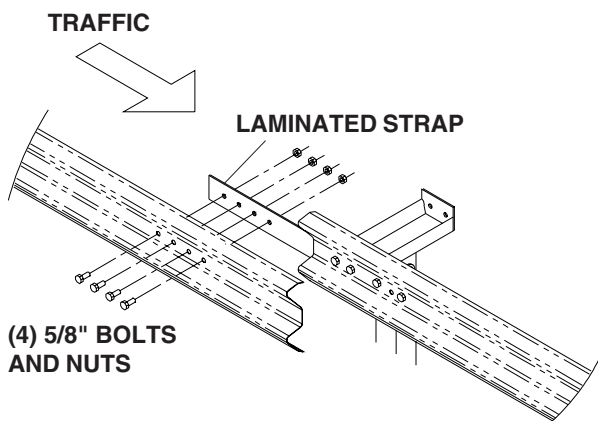

*Figure A-20*

Repeat previous steps until all diaphragms are installed.

Move the BTS into position at the front of System making sure it is oriented correctly (open C channel at the rear) (Figure A-21).

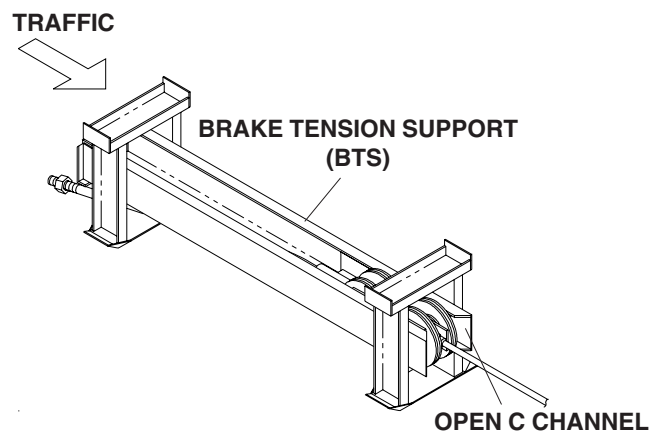

*Figure A-21*

Place the rear leg of the BTS between the remaining two fender panels and bolt the last set of straps to the rear attachments on the BTS in the same manner they were attached to the diaphragms (Figure A-22).

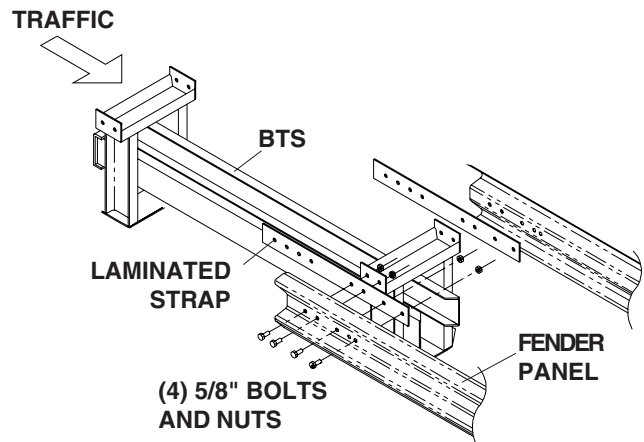

*Figure A-22*

Bolt the last two fender panels to the straps in the rear and directly to the attachments at the front of the BTS (Figure A-23). **Do not tighten the forward-most panel bolts at this time.**

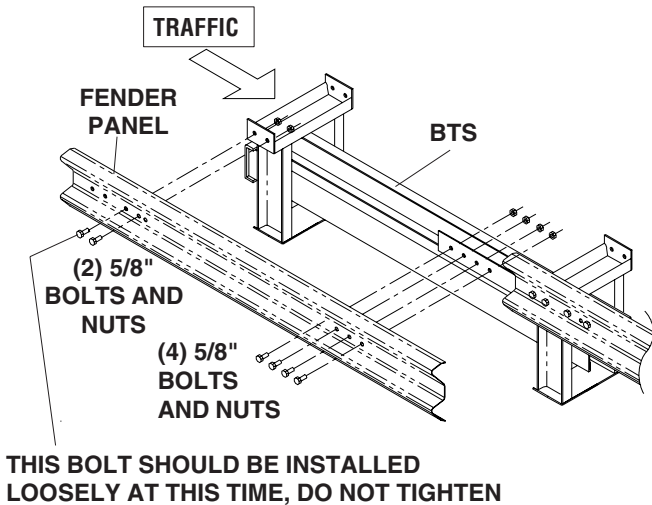

**Figure A-23**

*Note: The spacing between the rear of the anchor and the front of the BTS foot should be 63 to 127 mm [2-1/2" to 5"] (Figure A-24). See the System adjustment section of this manual if the spacing is not in this range. Be sure that the System length has been checked and adjusted if necessary.*

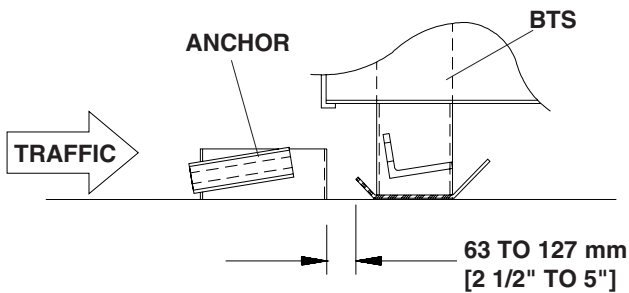

**Figure A-24**

Insert the 22 mm [7/8"] diameter x 711 mm [28"] long breakaway rods down through the bracket at the front inside of the BTS (Figure A-25).

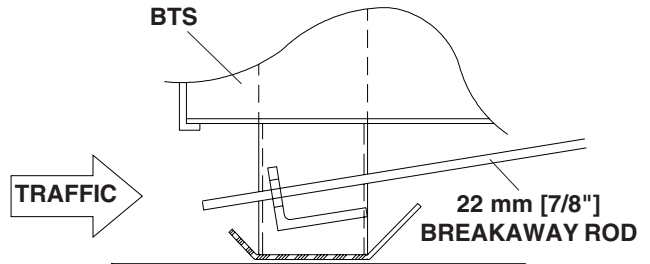

**Figure A-25**

Position the breakaway arm at the front side of the anchor. Thread one nut onto each rod far enough to allow the rods to extend down through the tubes in the anchor and through the breakaway arm. (Figure A-26).

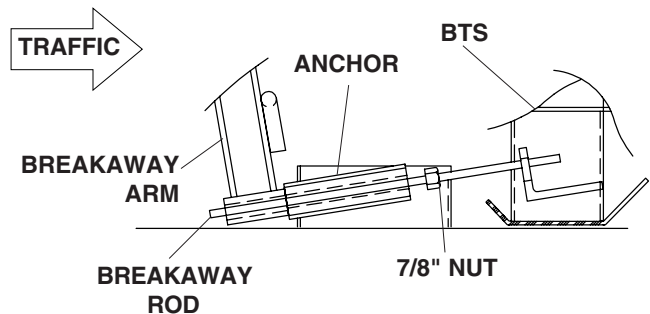

**Figure A-26**

# Brakemaster® 350

Continue bringing each rod down through the anchor and the breakaway arm until there is 25 mm [1"] extending out of the front of the breakaway arm tubes. Thread nuts onto the breakaway rods at the bottom of the breakaway arm, then thread nuts and washers onto other end of rods at the back side of the BTS bracket. Leave the nuts at the center of the breakaway rods loose and alternately adjust the nuts at the back side of the BTS bracket to approximately 80 Nm [60 ft-lbs] (Figure A-27).

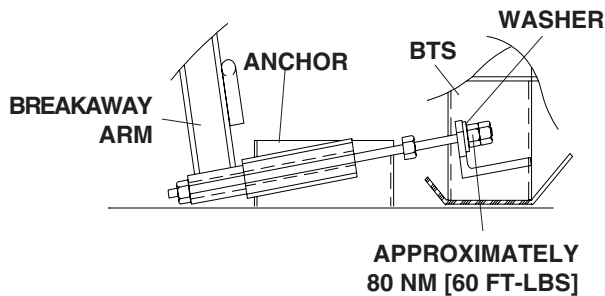

*Figure A-27*

Thread the nut at the center of each breakaway rod down to the tube on the anchor (Figure A-28). Torque each nut to approximately 80 Nm [60 ft-lbs].

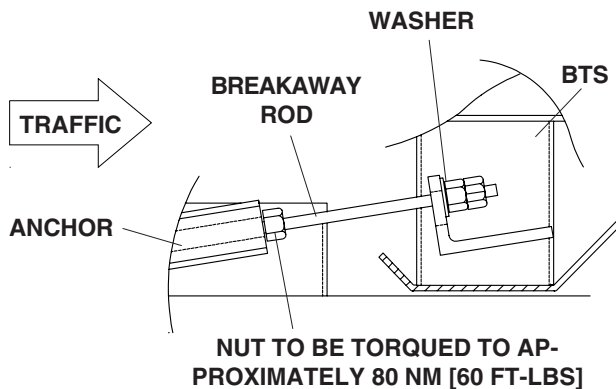

*Figure A-28*

Torque the double nuts on the breakaway rods at the back-side of the BTS bracket to approximately 80 Nm [60 ft-lbs].

Now that the System is tensioned, tighten all 58 exposed fender panel bolts to approximately 80 Nm [60 ft-lbs].

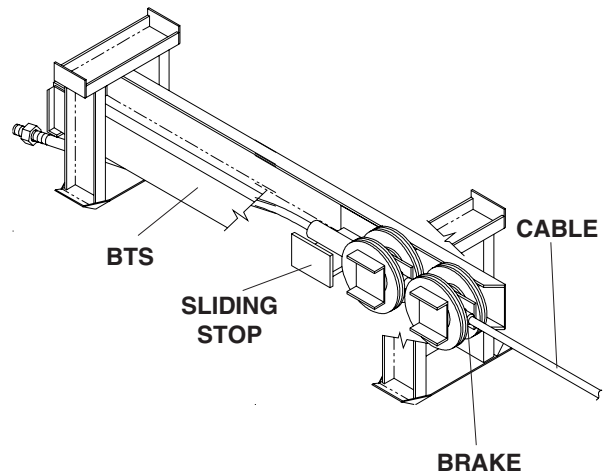

*Figure A-29*

Position the front end (short end) of the cable brake by feeding the brakes into the BTS (Figure A-29) and bringing the cable end out through the tube in the anchor approximately 150 -200 mm [6" - 8"] (Figure A-30). Lift the cable end and thread the cable nut approximately 19 - 25 mm [3/4" - 1"] past the end of the threaded stud.

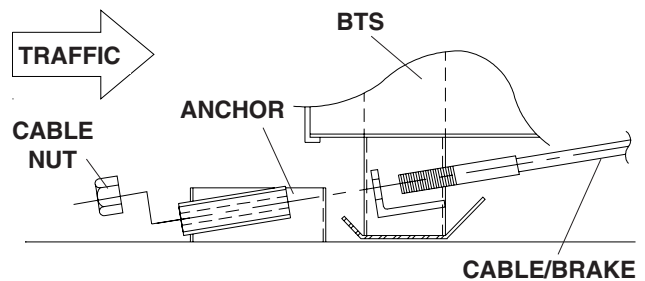
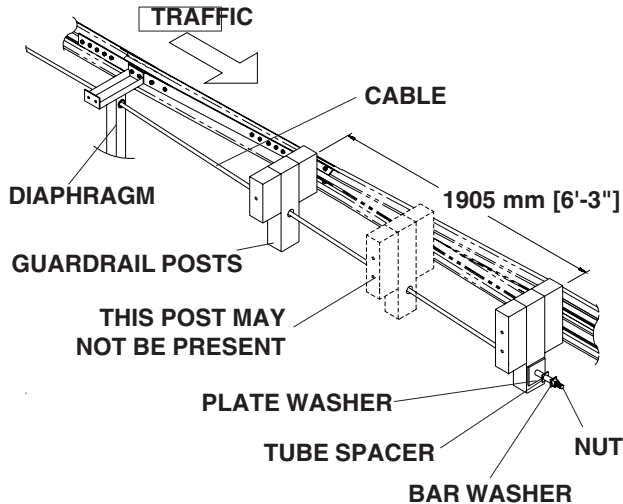

*Figure A-30*

Pull the front of the cable and brake assembly downstream until the nut is seated against the anchor then pull the rear end (long end) of the cable/brake through each of the holes in the diaphragm legs and through the holes in the guardrail posts (Figure A-31). Be sure the sliding stop is tight against the brakes.

The BRAKEMASTER® 350 System has an overall installation length tolerance of 50 mm [ $\pm 2$ "]. 100 mm [4"] long tube spacers and 6 mm [ $1/4$ "] thick bar washers are supplied to allow System adjustment.

Place the plate washer and as many bar washers/tube spacer combinations as needed on the cable end. Thread a nut on the rear end of the cable and hand tighten it. (Figure A-31). The cable must be held from turning during tightening.



**Figure A-31**

Pre-bend the sheet metal nose into an approximately 600 mm [2 ft] diameter semi-circle (Figure A-32). A smooth even bend is preferred. Be careful not to "kink" the sheet metal nose.

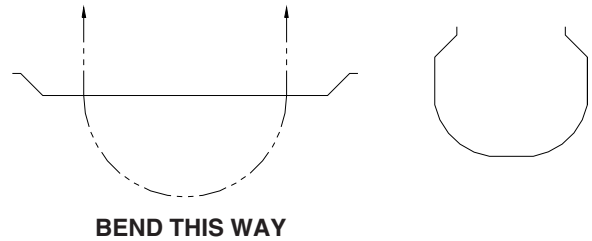

**Figure A-32**

Attach the center of the sheet metal nose to the breakaway arm with two Grade 5, 5/8" bolts, washers, and nuts (Figure A-33).

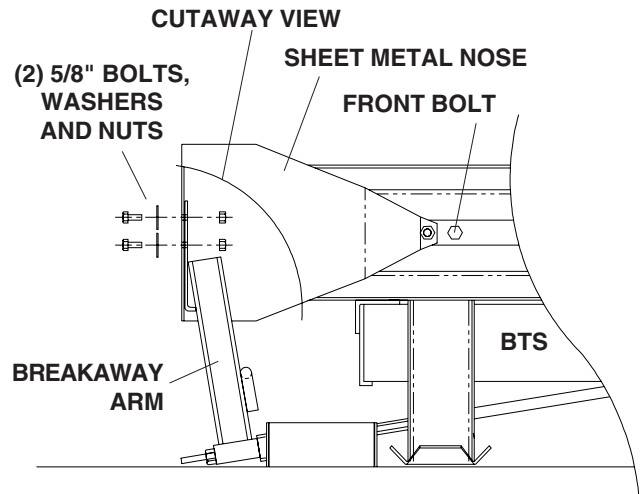

**Figure A-33**

Attach the ends of the sheet metal nose to the fender panels with the bolts that pass through the two front holes of the BTS (Figure A-33).

Proceed to "System Adjustment" on page 25.

# Brakemaster® 350

## Bidirectional Installation

*Note: The assembly of the bidirectional BRAKEMASTER System is done one side at a time. The right way traffic side is assembled first starting from the existing guardrail or transition section and working toward the BTS. The opposing traffic side is then assembled starting from the BTS and working back to the existing guardrail or transition section. All figures in this section show a left side bidirectional System. A right side bidirectional System would be assembled on opposite sides.*

Attach a transition strap to the inside of the right way traffic guardrail end with four Grade 5, 5/8" hex head bolts, washers and nuts (Figure A-34). Tighten the transition strap to approximately 80 Nm [60 ft-lbs].

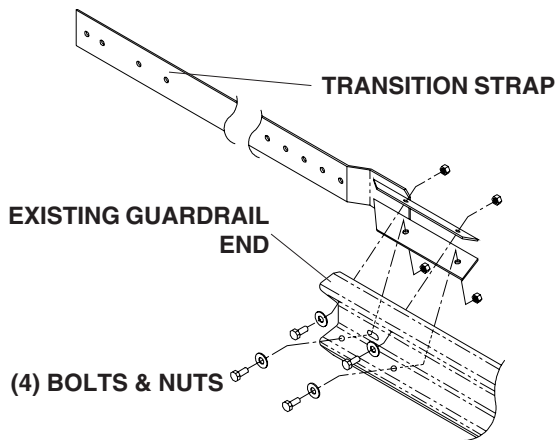

Figure A-34

*Note: Exercise caution during the assembly of the first side of the System as there might be a tendency for the panels and diaphragms to tip over.*

Attach a fender panel to the transition strap using five Grade 5, 5/8" hex head bolts and nuts (Figure A-35). The forward panel knockout hole must be used.

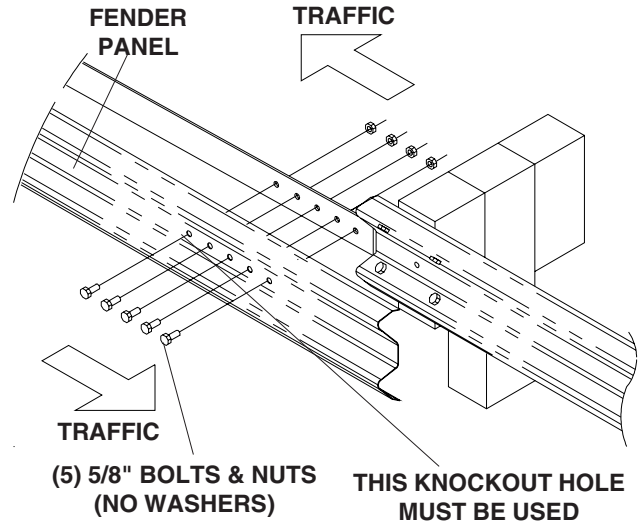

Figure A-35

Leave the nuts finger tight at this time.

**Caution: For proper impact performance, do not use washers on any of the panel connections.**

Position a diaphragm at the front end of the fender panel and place a solid 6 mm [1/4"] thick by 127 mm [5"] wide strap between the fender panel and the transition strap (Figure A-36).

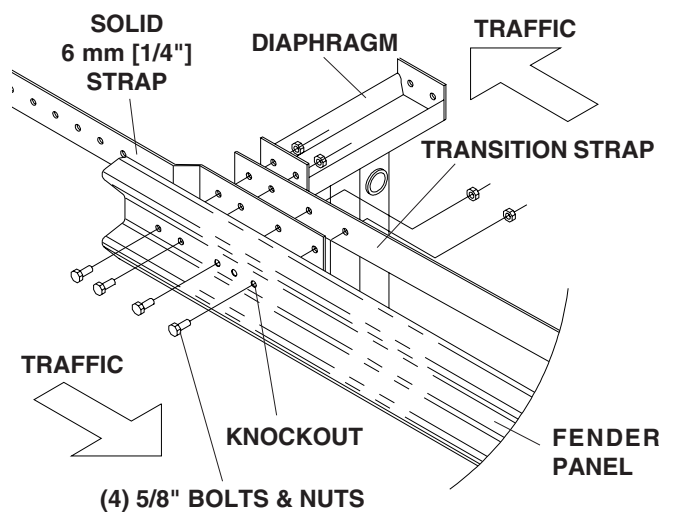

Figure A-36

Bolt the strap in place using four Grade 5, 5/8" bolts and nuts.

**Note:** Tighten the fender panel bolts to 80 Nm [60 ft-lbs] in the following sequence.

- a.) First tighten the bolts passing through the diaphragm.
- b.) Then tighten all other bolts.

Attach a fender panel to the exposed portion of the 6 mm [1/4"] thick strap using six Grade 5, 5/8" bolts and nuts (Figure A-37). Both fender panel knockout holes must be used.

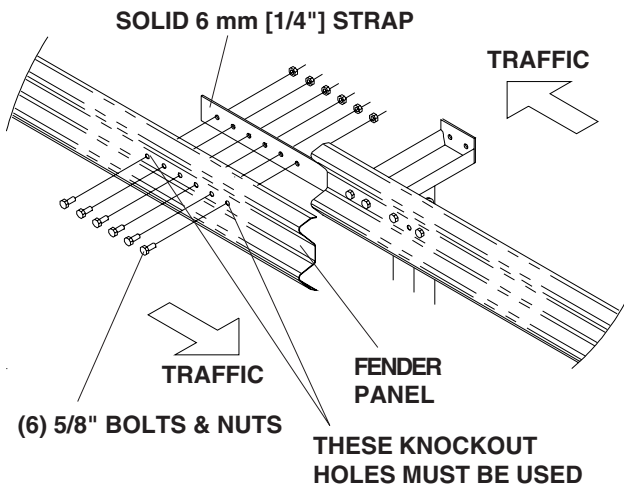

**Figure A-37**

Position another diaphragm at the front end of the fender panel and place a laminated strap between the panel and the diaphragm.

Bolt the laminated strap in place using four Grade 5, 5/8" bolts and nuts (Figure A-38).

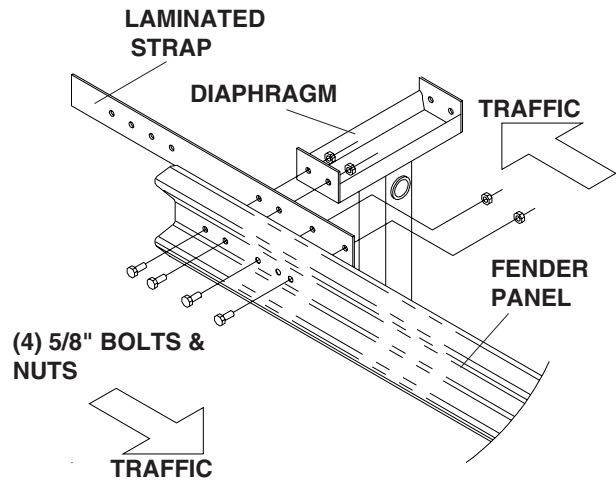

**Figure A-38**

Repeat the bolt tightening sequence per note (a) and (b) above.

Attach a fender panel to the exposed portion of the laminated strap using four Grade 5, 5/8" bolts and nuts (Figure A-39).

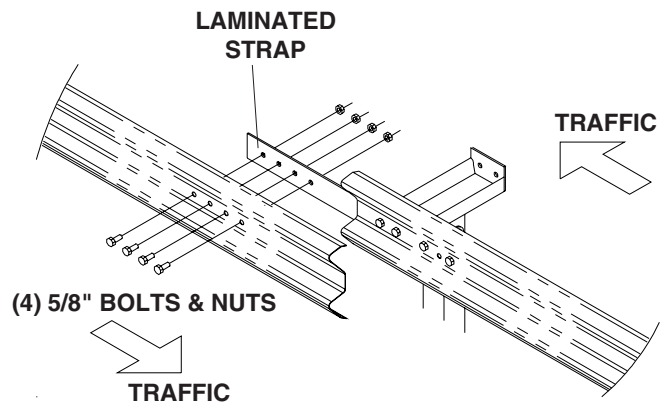

**Figure A-39**

# Brakemaster<sup>®</sup> 350

Repeat the previous steps until all diaphragms are installed. Move the BTS into position at the front of the System making sure it is oriented correctly (open C channel at the rear). (Figure A-40).

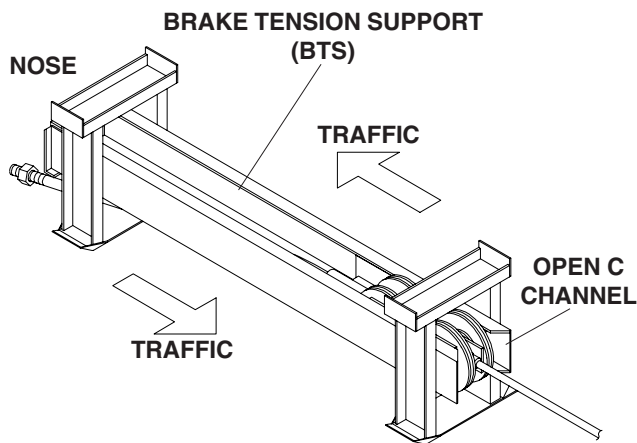

Figure A-40

Bolt a laminated strap to the rear attachment on the BTS in the same manner that they were attached to the diaphragms (Figure A-41).

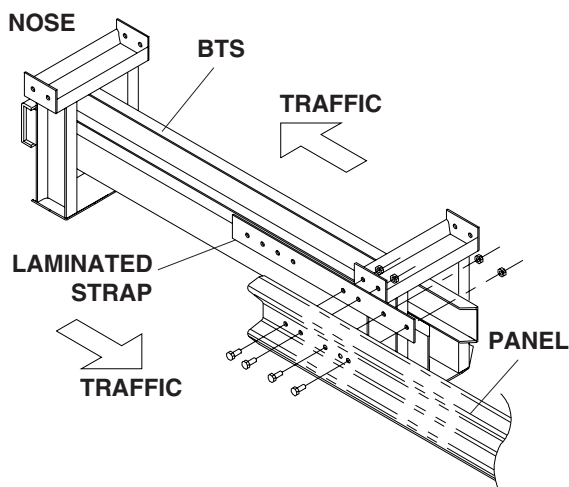

Figure A-41

Bolt a fender panel to the laminated strap in the rear and directly to the attachment at the front of the BTS (Figure A-42). **Do not tighten the forward-most panel bolts at this time.**

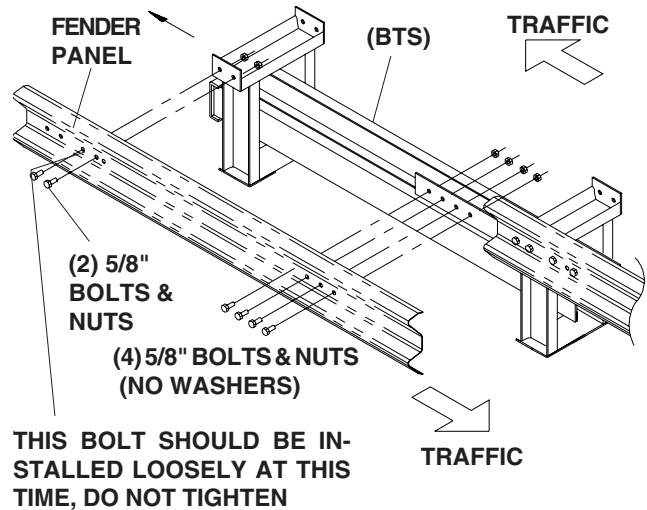

Figure A-42

*Note: The spacing between the rear of the anchor and the front of the BTS foot should be 63 to 127 mm [2 1/2" to 5"] (Figure A-43). See the System adjustment section of this manual if the spacing is not in this range. Be sure that the System length has been checked and adjusted if necessary.*

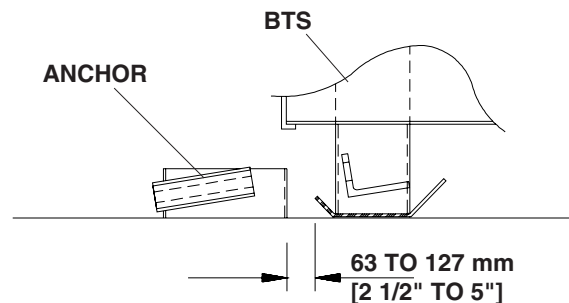
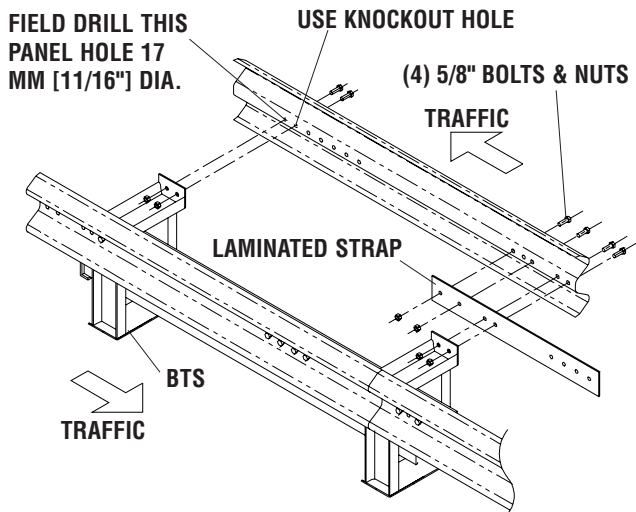

Figure A-43

Now move to the opposite side of the System. Bolt a laminated strap and fender panel to the rear of the BTS (Figure A-44). At the front of the System one 17 mm [11/16"] diameter hole will need to be drilled in the fender panel to match the hole location in the front of the BTS. Spray cold galvanize on this match drilled hole.



**Figure A-44**

Attach a panel to the exposed portion of the laminated strap using four Grade 5, 5/8" bolts and nuts. Bolt a laminated strap between the diaphragm and the fender panel using four Grade 5, 5/8" bolts and nuts (Figure A-45).

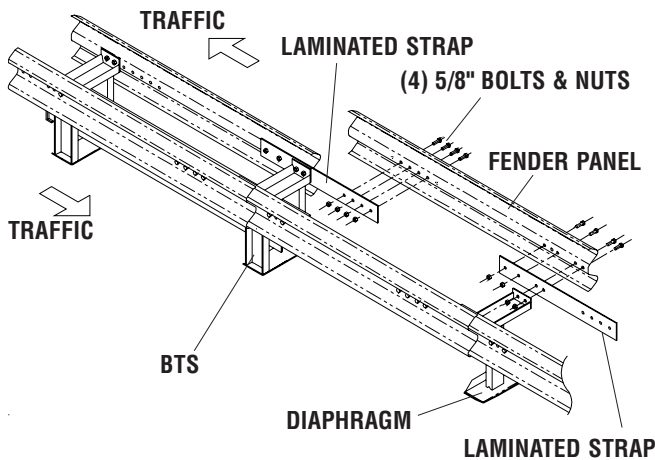

**Figure A-45**

Repeat the bolt tightening sequence per note (a) and (b) from page 19.

Attach a fender panel to the exposed portion of the laminated strap using four Grade 5, 5/8" bolts and nuts. Bolt a 6 x 127 mm [1/4" x 5"] solid strap between the fender panel and the diaphragm using four Grade 5, 5/8" bolts and nuts (Figure A-46).

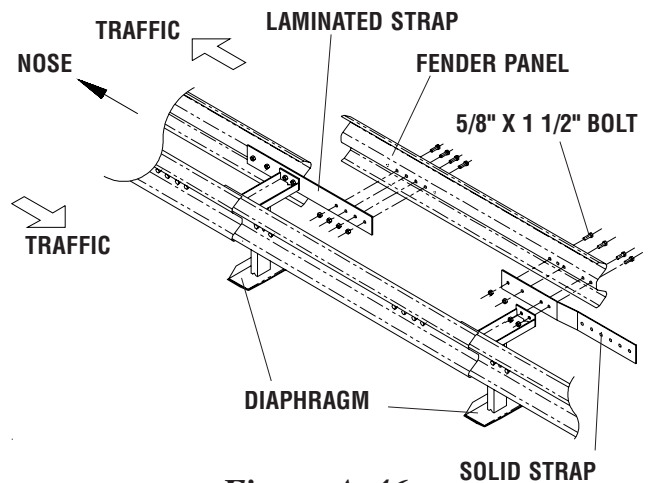

**Figure A-46**

Repeat the bolt tightening sequence per notes (a) and (b) on page 19.

Attach a panel to the exposed portion of the 1/4" solid strap using six Grade 5, 5/8" bolts and nuts. Bolt a 6 mm [1/4"] solid strap between the diaphragm and the fender panel (Figure A-47). Both panel knockout holes must be used.

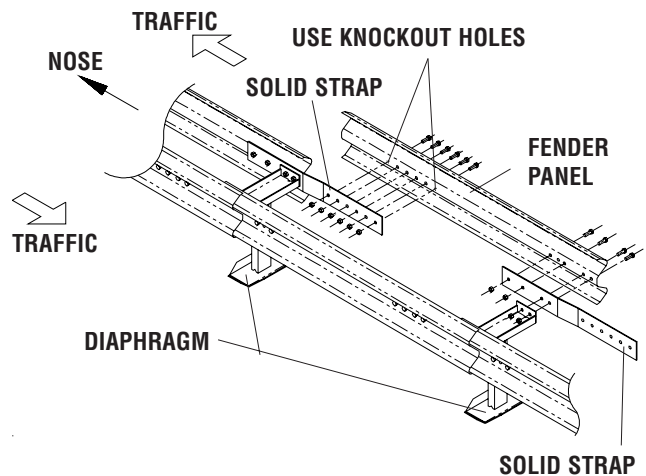

**Figure A-47**

# Brakemaster® 350

Bolt the last fender panel to the 6 mm [1/4"] solid strap using six Grade 5, 5/8" bolts and nuts. Locate and match drill a 17 mm [11/16"] diameter hole through the fender panel at the post bolt location (Figure A-48). Spray cold galvanize on this match drilled hole.

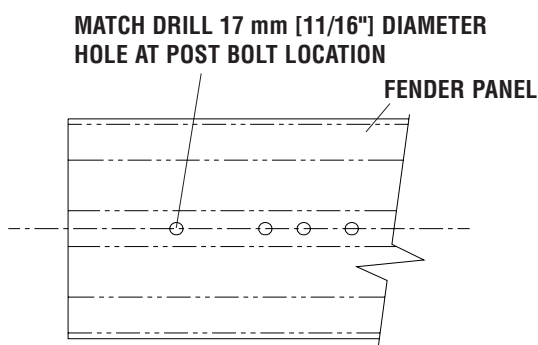

**Figure A-48**

Disassemble the existing guardrail connection point, then reassemble the guardrail making sure that the fender panel is under the existing guardrail (Figure A-49).

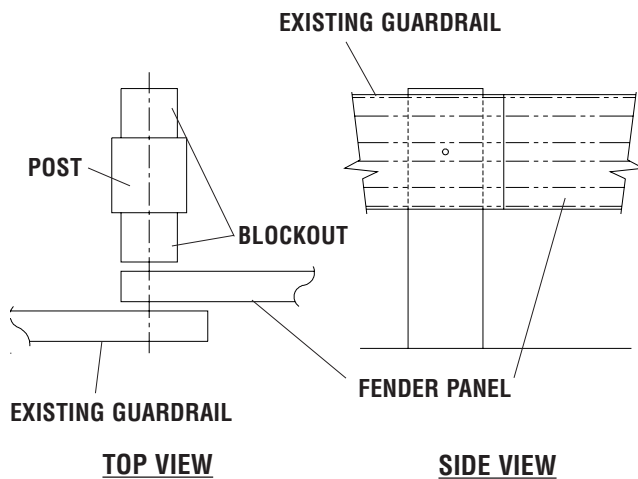

**Figure A-49**

Straighten the System by aligning the components from the front anchor to the rear of the System. Match drill four 17 mm [11/16"] diameter holes on the centerline of the post through the existing guardrail and fender panel (Figure A-50). Spray cold galvanize on these four match drilled holes. Install four Grade 5, 5/8" bolts with the nuts on the inside.

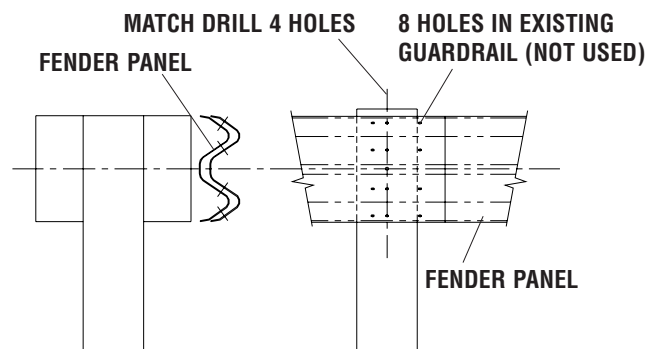

**Figure A-50**

**Caution: The match drilled hole locations should be 100-130 mm [4-5"] from the ends of both the fender panel and the guardrail.**

Insert the 22 mm [7/8"] diameter x 711 mm [28"] long breakaway rods down through the bracket at the front inside of the BTS (Figure A-51).

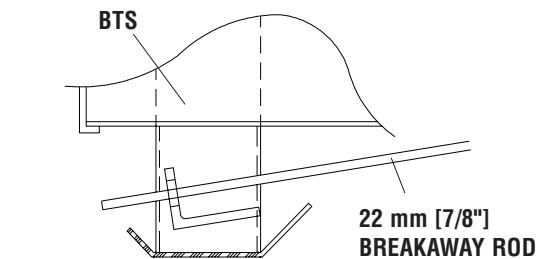

**Figure A-51**

Position the breakaway arm at the front side of the anchor. Thread one nut onto each rod far enough to allow the rods to extend down through the tubes in the anchor and through the breakaway arm (Figure A-52).

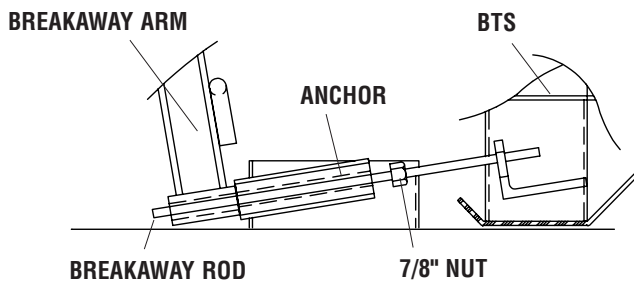

**Figure A-52**

Continue bringing each rod down through the anchor and the breakaway arm until there is 25 mm [1"] extending out of the front of the breakaway arm tubes. Thread nuts onto the breakaway rods at the bottom of the breakaway arm, then thread nuts and washers onto other end of rods at the back side of the BTS bracket. Leave the nuts at the center of the breakaway rods loose and alternately adjust the nuts at the back side of the BTS bracket to approximately 80 Nm [60 ft-lbs] (Figure A-53).

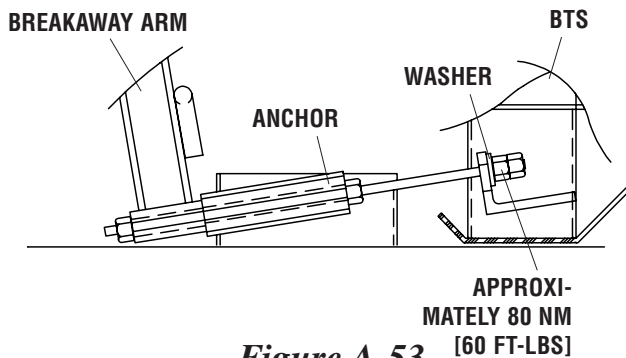

**Figure A-53**

Turn the nut at the center of each breakaway rod down to the tube on the anchor (Figure A-54). Torque these nuts to approximately 80 Nm [60 ft-lbs].

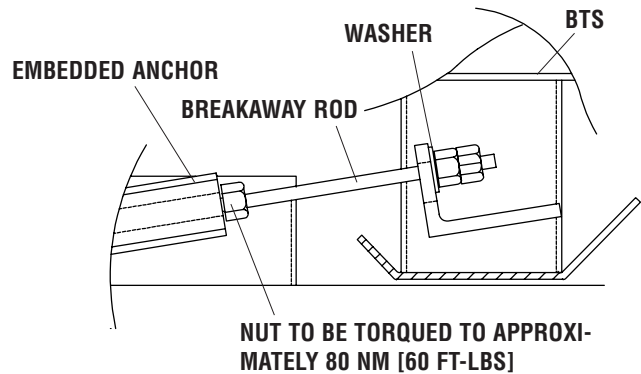

**Figure A-54**

Tighten the nuts on the breakaway rods at the backside of the BTS bracket to approximately 80 Nm [60 ft-lbs].

Now that the System is tensioned, tighten all 59 exposed panel bolts to approximately 80 Nm [60 ft-lbs].

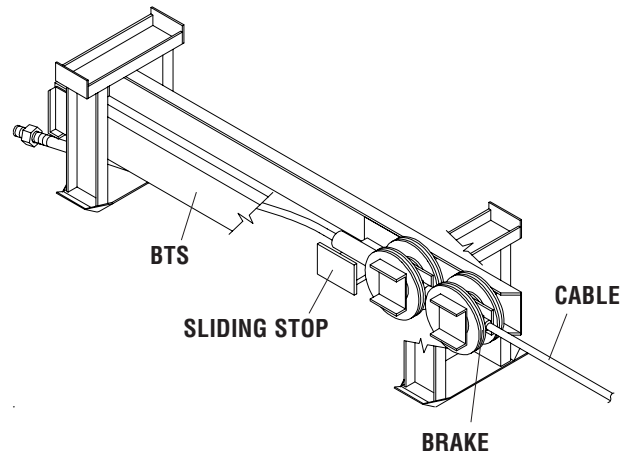

**Figure A-55**

Position the front end (short end) of the cable/brake by feeding the brakes into the BTS (Figure A-55) and bringing the cable end out through the tube in the anchor approximately 150-200 mm [6" - 8"] (Figure A-56). Lift the cable end and turn the cable nut approximately 19-25 mm [3/4" - 1"] past the end of the threaded stud.

# Brakemaster® 350

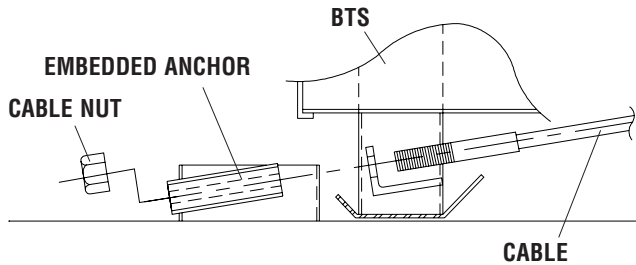
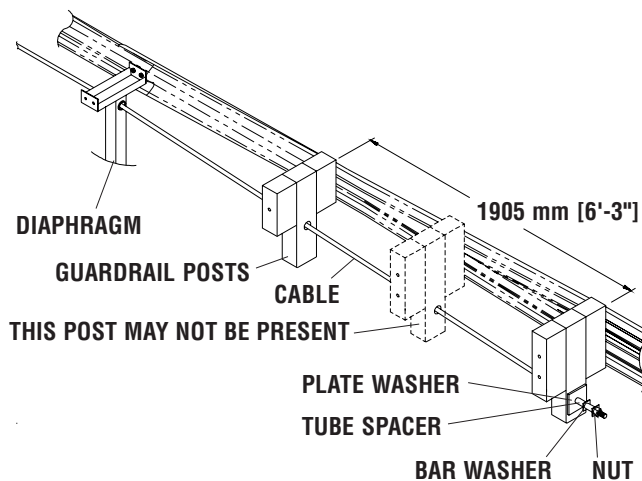

**Figure A-56**

Pull the front of the cable and brake assembly downstream until the nut is seated against the anchor then pull the rear end (long end) of the cable/brake through each of the holes in the diaphragm legs and through the holes in the guardrail posts. Be sure the sliding stop is tight against brakes.

The BRAKEMASTER System has an overall installation length tolerance of +/- 150 mm [+/- 6"]. 102 mm [4"] long tube spacers and 6 mm [1/4"] thick bar washers are supplied to allow System adjustment (Figure A-57).

Place the plate washer and as many bar washers/tube spacer combinations as needed on the cable end. Thread a nut on the rear end of the cable and hand tighten it (Figure A-57). The cable must be held from turning during tightening.



**Figure A-57**

Pre-bend the sheet metal nose into an approximately 600 mm [2 ft] diameter semi-circle. (Figure A-58) A smooth even bend is preferred. Be careful not to "kink" the sheet metal nose.

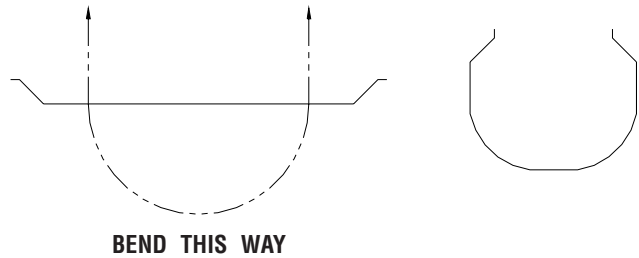

**Figure A-58**

Attach the center of the sheet metal nose to the breakaway arm with two Grade 5, 5/8" bolts, washers and nuts (Figure A-59).

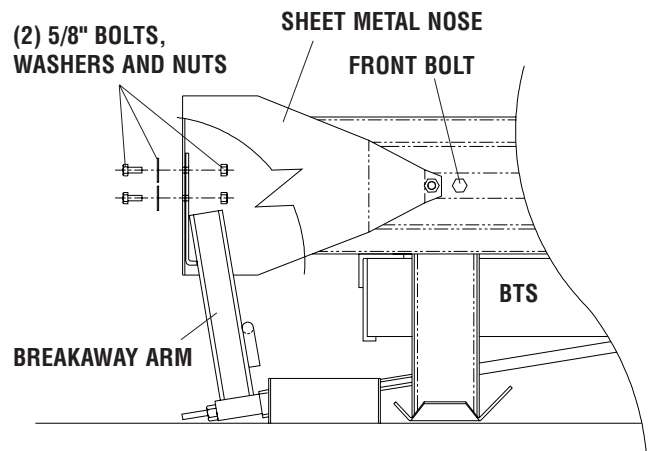

**Figure A-59**

Attach the ends of the sheet metal nose to the fender panels with bolts that pass through the two front holes of the BTS (Figure A-59).

Proceed to "System Adjustment" on page 25.

## System Adjustment

If the System is not positioned 63-127 mm [2 1/2" to 5"] between the rear of the anchor and the front of the BTS, the length of the System will need to be adjusted accordingly. This adjustment is accomplished by using the knockout holes in the fender panels of bays 2 and 3 (Figure 60). These two bays each have a System length adjustment of +/-76 mm [+/- 3"]. By utilizing the knockouts in both bays 2 and 3 the total System has an overall length adjustment of +/- 150 mm [+/- 6"] (Figure 61).

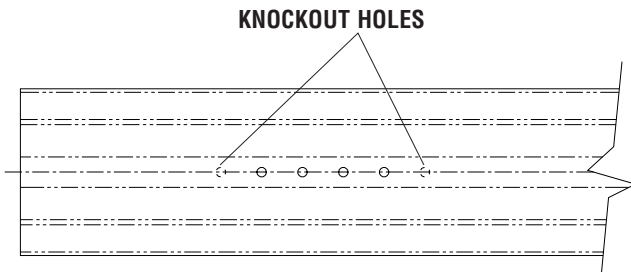

*Figure 60*

**Caution: For proper impact performance make System length adjustments on bays 2 and 3 only.**

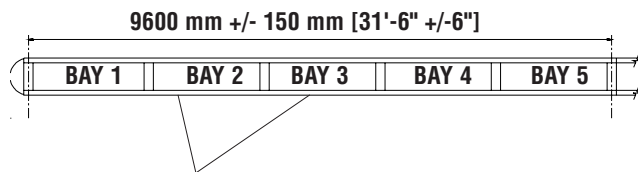

**ONLY UTILIZE THESE TWO BAYS FOR SYSTEM OVERALL LENGTH ADJUSTMENT**

*Figure 61*

## Checking the System Assembly

After completing the installation of the System, recheck to ensure that all fasteners are torqued to approximately 80 Nm [60 ft-lbs] throughout the System.

# Brakemaster<sup>®</sup> 350

## Maintenance Checklist

How often Maintenance is required will depend upon site conditions. Visual Drive-By Inspections are recommended at least once a month. Walk-Up Inspections are recommended at least once a year.

### Visual Drive-by Inspection

- 1) Check to see if there is any evidence of an impact (deformed nose or side panels). If so, a walk-up inspection will be necessary.
- 2) Check to see that the surface under the System is clear of debris to ensure proper performance.
- 3) Note the location, condition of the Brakemaster 350 System and the date of the visual drive-by inspection. Drive-by inspections are recommended on an as needed basis based upon traffic volume, site accident history, etc.

### Walk-Up Inspection

- 1) Be sure all bolts are tight and rust-free. All bolts should be torqued to 100 +/- 10 ft-lbs. [136 +/- 14 Nm] or tighten nut 1/4 turn past snug.
- 2) Be sure the restraining cable is snug and rust-free.
- 3) Check to see that the threaded rods on the front of the breakaway assembly are intact and that the nuts on the rods are properly torqued to 100 +/- 10 ft-lbs. [136 +/- 14 Nm] or tighten nut 1/4 turn past snug.
- 4) Check to see that the brake assembly has not moved on the cable. Both brakes must be on the cable sleeve and they must be positioned in the c-channel at the rear of the Brake/Tension Support.
- 5) Check to see that the laminated straps, the solid straps and the transition straps at the fender panel connection points are installed correctly with bolts in all available holes.
- 6) Check to make sure that the diaphragm legs are on grade level and clear of debris.
- 7) Clear any and all debris from the Brakemaster 350 System site area.
- 8) Note the location and condition of the Brakemaster 350 System for entry in the impact attenuator inspection logbook under the date of this inspection. Walk-up inspections are recommended on an as needed basis based upon traffic volume, site accident history, etc.
- 9) Refer to Post-Impact Repositioning instructions and installation manual for more information.

# Post-Impact Instructions

## Tools Required

1. This installation manual
2. Installation plans (prints) for this type of System
3. Crescent wrenches (two 300 mm [12"])
4. Pipe wrenches (two 600 mm [24"])
5. 1/2" or 3/4" drive ratchet with extension,
6. 15/16", 1 1/4", 1 3/8" and 1 7/16" deep sockets
7. 15/16" and 1 3/8" combination wrenches
8. Drift pin (to align holes)
9. Boom or forklift with minimum 700 Kg [1500 lb] capacity (recommended for handling packaged System and for positioning the Brake/Tension Support)
10. Gas welder with cutting torch (recommended if transition modifications are required)
11. 15,000 mm [50'] tape measure
12. Generator
13. Traffic control equipment
14. Drill motor with 50 mm [2"] dia. wood auger bit and 18 mm [11/16"] drill bit
15. Drilling rig with 600 mm [2'] dia auger for 1500 mm [5'] deep hole
16. Gloves
17. Chalk line
18. Safety glasses
19. Bubble level

## Procedure

- 1) Deploy the appropriate traffic-control devices to protect your crew.
- 2) Clear and dispose of any debris on the site.
- 3) Check all components of the Brakemaster® 350 System and transition; any components that are bent or damaged must be replaced. After a design speed impact on the nose, it is possible that the only parts that will be reusable are the brake/tension support and the front anchor.
- 4) To refurbish the Brakemaster 350 System, disassemble the System and replace the damaged parts with new parts.
- 5) If the front anchor has moved more than 76 mm [3"] - move it back to position and backfill with loose sand or concrete.
- 6) The cable/brake assembly must be replaced if the cable sleeve is exposed.
- 7) During the process of refurbishment, follow the Installation Instructions.
- 8) Check to be certain that the site is free from any debris. The Brakemaster 350 System is now ready to be used again.

## Parts Ordering Procedure

- 1) Make a list of all damaged parts using the part descriptions and part numbers shown on pages 28-32.
- 2) The customer has the option of returning the cable/brake assembly for credit. Follow the standard return goods procedure.
- 3) Contact the Energy Absorption Systems' **Customer Service Department at (888) 32-ENERG** for parts orders and for answers to any questions.

# Brakemaster® 350

## BRAKEMASTER 350 SYSTEM UNIDIRECTIONAL INSTALLATION SHOWN

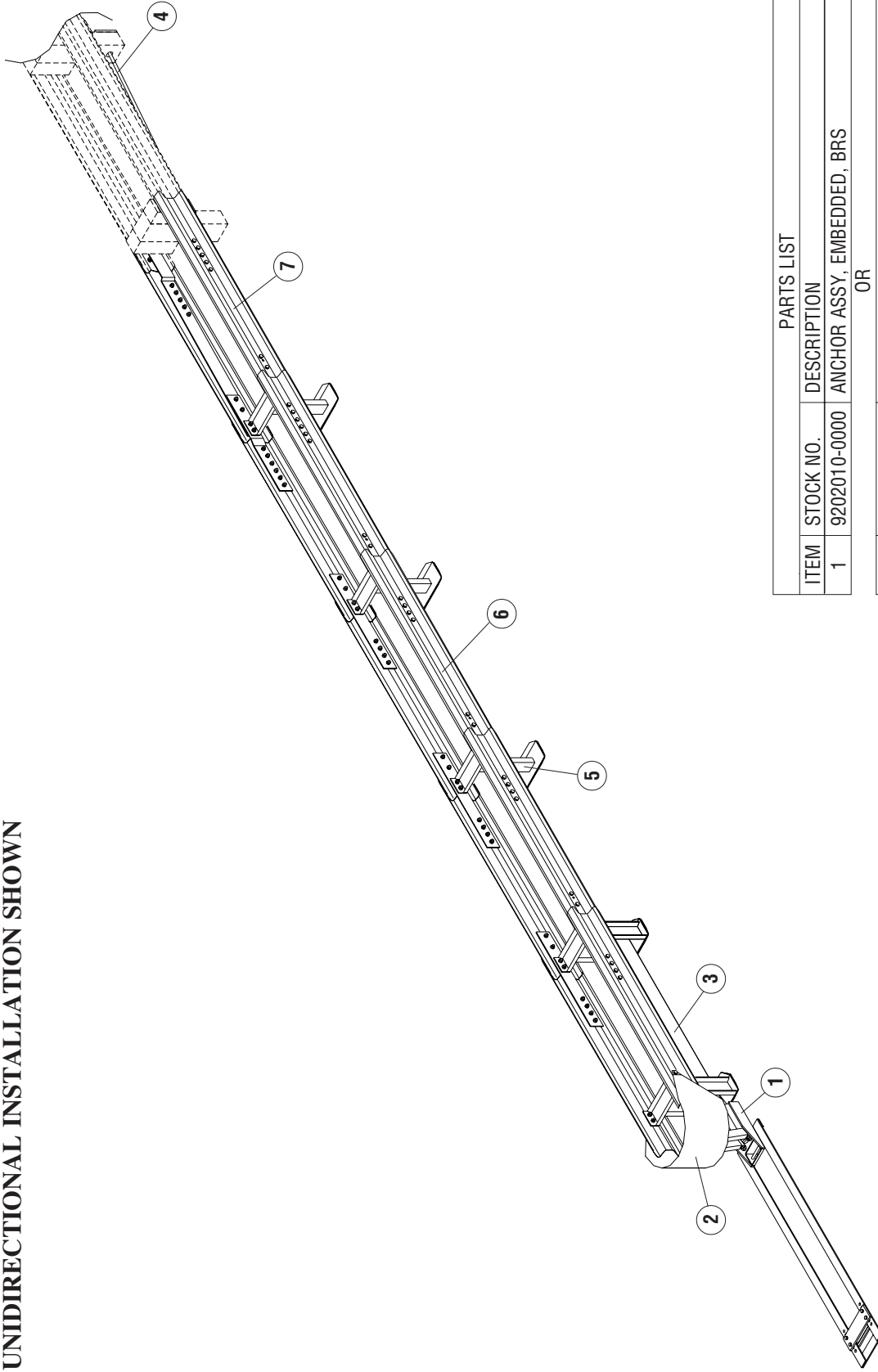

PARTS LIST	
ITEM	STOCK NO. DESCRIPTION
1	9202010-0000 ANCHOR ASSY, EMBEDDED, BRS
OR	
1	9202024-0000 ANCHOR ASSY, FOUNDATION TUBE
2	9204010-0000 BREAKAWAY ASSY
3	9206010-0000 BRAKE/TENSION SUPPORT ASSY
4	9208010-0000 CABLE/BRAKE ASSY
5	9210011-0000 DIAPHRAGM, BRS
6	9212010-0000 PANEL/STRAP ASSY
7	9214010-0000 TRANSITION STRAP ASSY

### ANCHOR ASSEMBLY, EMBEDDED, BRS

PARTS LIST (ASSY NO. 9202010-0000)		
ITEM	DESCRIPTION	QTY
1	ANCHOR, EMBEDDED, BRS	1
2	SUPPORT, WOOD, 1 x 4 x 48	2
3	SCREW, HXW, 1/4 x 1 3/4, G	4
4	WASHER, FLAT, 1/4 x 1 1/2, G	4
5	NUT, WASHER, G	4

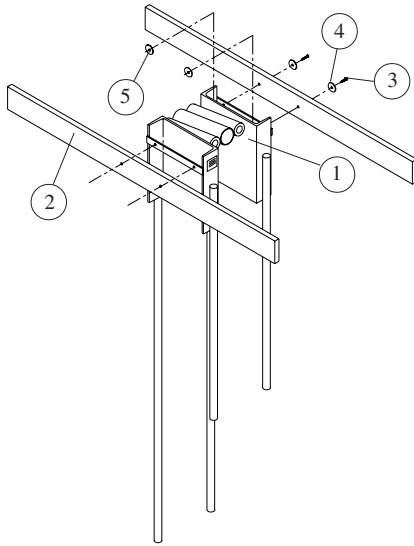

### PARTS LIST (ASSY NO. 9202024-0000)

ITEM	DESCRIPTION	QTY
1	ANCHOR, ADAPTER, BTS	1
2	ANCHOR STRAP, BRS	1
3	FOUNDATION TUBE, 78, BRS	2
4	BOLT, HX, 5/8X10, G5, G	2
5	NUT, HX, 5/8, G, RAIL	6
6	ANCHOR PLUG, FOUND. TUBE	1
7	BOLT, HX, 5/8X2, G2, G	4

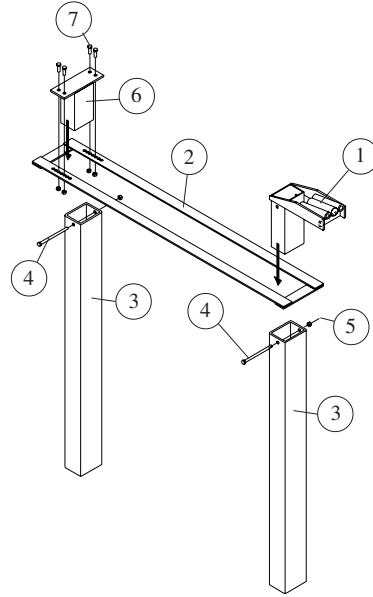

### PANEL/STRAP ASSEMBLY

PARTS LIST (ASSY NO. 9212010-0000)			
ITEM	STOCK NO.	DESCRIPTION	QTY
1	9212021-0000	PANEL, FENDER, BRS	1
2	9216021-0000	STRAP, LAMINATED	1
3	2699081-0500	BOLT, HX, 5/8x1 1/2, G5, G	8
4	2704191-0000	NUT, HX, 5/8, G, RAIL	8

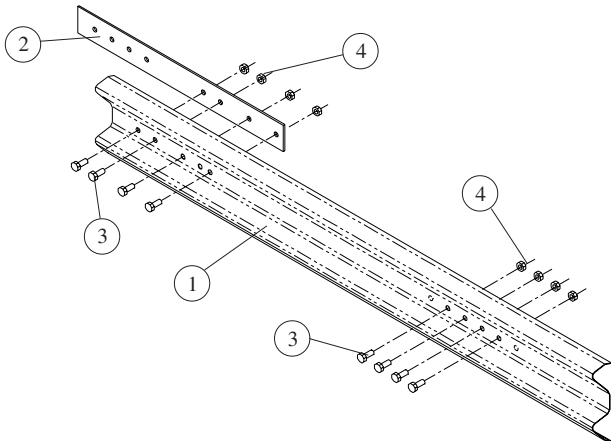

### DIAPHRAGM, BRS PART NO. 9210011-0000

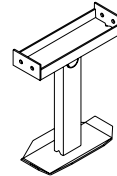

# Brakemaster<sup>®</sup> 350

## BRAKE/TENSION SUPPORT ASSEMBLY

PARTS LIST (ASSY NO. 9206010-0000)			
ITEM	STOCK NO.	DESCRIPTION	QTY
1	9206021-0000	BRAKE/TENSION SUPPORT	1
2	9212021-0000	PANEL,FENDER,BRS	2
3	2699081-0500	BOLT,HX,5/8x1 1/2,G5,G	12
4	2704191-0000	NUT,HX,5/8,G,RAIL	12

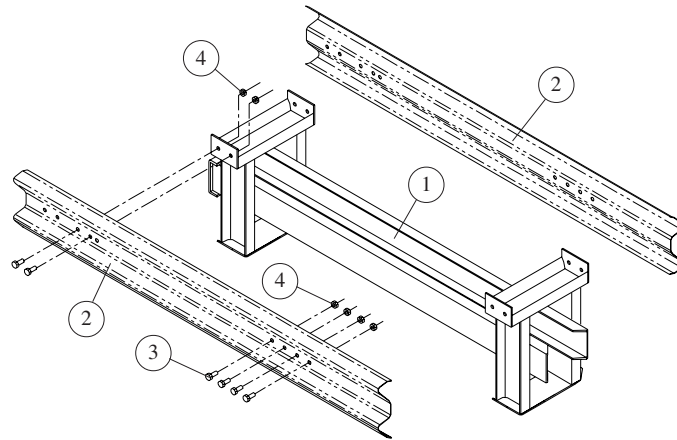

## CABLE/BRAKE ASSEMBLY

PARTS LIST			
ITEM	STOCK NO.	DESCRIPTION	QTY
1	NOT AVAILABLE	BRAKE ASSY,BRS	2
2	SEPARATELY	CABLE ASSY,BRS	1
3	2708671-0000	WASHER,BAR,3/4x8x8	1
4	2708491-0000	WASHER,BAR,1/4x3x3,G	3
5	9208101-0000	SPACER,BRS	3

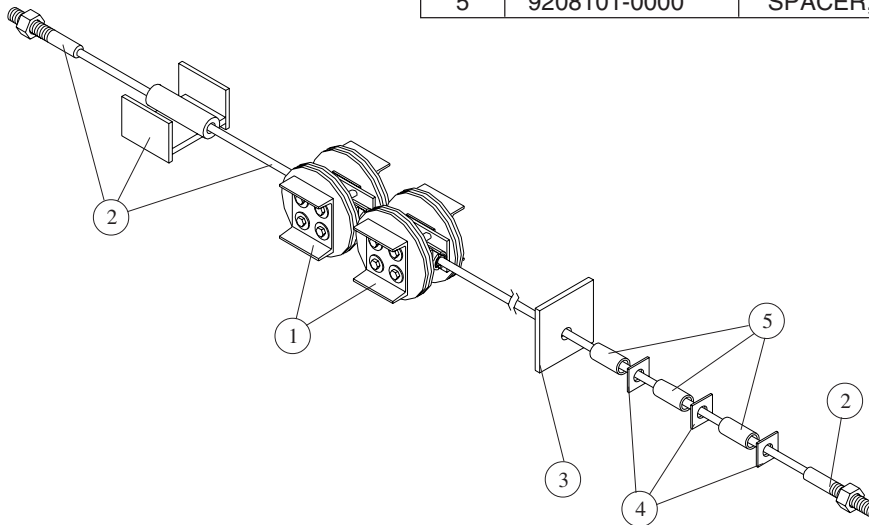

## BREAKAWAY ASSEMBLY

PARTS LIST (ASSY NO. 9204010-0000)			
ITEM	STOCK NO.	DESCRIPTION	QTY
1	9204021-0000	NOSE, BRS	1
2	9204031-0000	BREAKAWAY ARM	1
3	2699272-0500	ROD, THREADED, 7/8 x 28, G5, G	2
4	2704441-0000	NUT, HX, 7/8, G, GR DH	8
5	2708291-0000	WASHER, FLAT, 5/8 x 1 3/4, G	2
6	2699081-0500	BOLT, HX, 5/8 x 1 1/2, G5, G	2
7	2704191-0000	NUT, HX, 5/8, G, RAIL	2
8	2708301-0000	WASHER, FLAT, 7/8X2 1/4, G	2

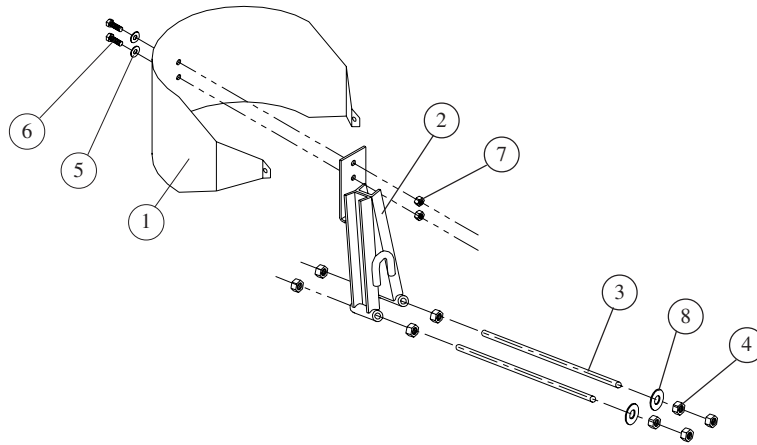

## TRANSITION STRAP ASSEMBLY

PARTS LIST (ASSY NO. 9214010-0000)			
ITEM	STOCK NO.	DESCRIPTION	QTY
1	9214021-0000	STRAP, TRANSITION	1
2	9218011-0000	STRAP, SOLID	1
3	9212021-0000	PANEL, FENDER, BRS	1
4	2699081-0500	BOLT, HX, 5/8 x 1 1/2, G5, G	15
5	2704191-0000	NUT, HX, 5/8, G, RAIL	15
6	2708291-0000	WASHER, FLAT, 5/8 x 1 3/4, G	4

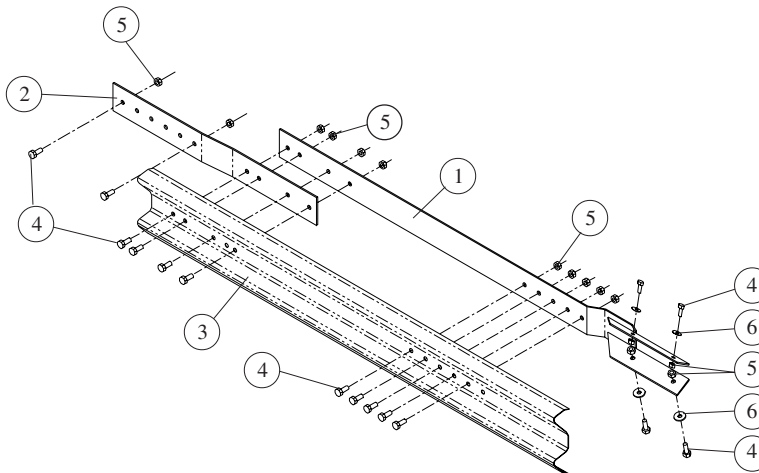

# Brakemaster® 350

## Limitations And Warnings

The BRAKEMASTER® System has been tested and evaluated per the recommendations of the National Cooperative Highway Research Program (NCHRP) report 350.\* The BRAKEMASTER System as currently designed, is capable of: decelerating and stopping light and heavy weight vehicles (820 to 2000 kg [1804 and 4400 lb]) when impacted head-on at 100 km/h [62.1 mph]; and redirecting light and heavy weight vehicles (820 to 2000 kg [1804 and 4400 lb]) when impacted at 100 km/h [62.1 mph] along the System's side for right way impacts of 20 degrees or less and wrong way impacts at an angle of 20 degrees or less. Tests are conducted on slopes less than 8 degrees and without curbs.

A smooth transition must be provided when attaching the BRAKEMASTER System to a rigid object. This transition may be purchased as an extra piece of hardware from Energy Absorption Systems or provided by the customer.

Refer to the BRAKEMASTER System Maintenance Manual for components needing replacement after partial impacts to ensure the energy absorbing capacity of the System has not been adversely impaired.

Excessive curb height may create a ramping effect, which could create an unsafe vehicle trajectory.

Impacts that exceed the design capabilities described in this manual (vehicle weight, speed and impact angle) may not result in acceptable crash performance as described in NCHRP 350 relative to structural adequacy, occupant risk and vehicle trajectory factors.

\* **Copy may be obtained from:**  
Transportation Research Board  
National Research Council  
2101 Constitution Avenue, N.W.  
Washington, D.C. 20418

# Notes

# Brakemaster<sup>®</sup> 350

## Notes

# Notes

---

**Customer Service Department**

**USA**

**Phone 1-888-323-6374**

**Fax 1-312-467-1356**

**Asia Pacific**

**Phone +65 6276 3398**

**Fax +65 6276 6218**

**Europe**

**Phone +44-1473-221-105**

**Fax +44-1473-221-106**

**35 East Wacker Dr., 11th Floor  
Chicago, IL 60601-2076  
Engineering and Manufacturing Facilities:  
Rocklin, California and Pell City, Alabama**



**ENERGY ABSORPTION**  
*SYSTEMS, INC.*

**A Quixote Company  
Saving Lives By Design**

Rev. 7/22/05

<http://www.energyabsorption.com/>

Part No. 2735761-0000

© 2005 Energy Absorption Systems, Inc.